



Translators to Higher Order Mean Curvature Flows in $\mathbb{R}^n \times \mathbb{R}$ and $\mathbb{H}^n \times \mathbb{R}$

Ronaldo F. de Lima¹ · Giuseppe Pipoli²

Received: 20 April 2024 / Accepted: 13 January 2025
© Mathematica Josephina, Inc. 2025

Abstract

We consider translators to the extrinsic flows in $\mathbb{R}^n \times \mathbb{R}$ and $\mathbb{H}^n \times \mathbb{R}$ (called r -mean curvature flows or r -MCF, for short) whose velocity functions are the higher order mean curvatures H_r . We show that there exist rotational bowl-type and catenoid-type translators to r -MCF in both $\mathbb{R}^n \times \mathbb{R}$ and $\mathbb{H}^n \times \mathbb{R}$, and also that there exist parabolic and hyperbolic catenoid-type translators to r -MCF in $\mathbb{H}^n \times \mathbb{R}$. In addition, we show that there exist grim reaper-type translators to Gaussian flow (n -MCF) in $\mathbb{R}^n \times \mathbb{R}$ and $\mathbb{H}^n \times \mathbb{R}$. We also establish the uniqueness of all these translators (together with certain cylinders) among those which are invariant by either rotations or translations (Euclidean, parabolic or hyperbolic). We apply this uniqueness result to classify the translators to r -MCF in $\mathbb{R}^n \times \mathbb{R}$ and $\mathbb{H}^n \times \mathbb{R}$ whose r -th mean curvature is constant, as well as those which are isoparametric. Our results extend to the context of r -MCF in $\mathbb{R}^n \times \mathbb{R}$ and $\mathbb{H}^n \times \mathbb{R}$ the existence and uniqueness theorems by Altschuler–Wu (of the bowl soliton) and Clutterbuck–Schnürer–Schulze (of the translating catenoids) in Euclidean space.

Keywords Translators · Higher order mean curvature · Invariant hypersurfaces · Product space

Mathematics Subject Classification 53E40 (primary) · 53C42 · 53C45 (secondary)

1 Introduction

Extrinsic geometric flows of hypersurfaces in Riemannian manifolds is a most prominent topic in submanifold theory. Such a flow is generated by a hypersurface moving

✉ Ronaldo F. de Lima
ronaldo.freire@ufrn.br

Giuseppe Pipoli
giuseppe.pipoli@univaq.it

¹ Departamento de Matemática, Universidade Federal do Rio Grande do Norte, Natal, Brazil

² Department of Information Engineering, Computer Science and Mathematics, Università degli Studi Dell’Aquila, L’Aquila, Italy

in the direction of its normal vector with speed given by a smooth symmetric function of its principal curvatures. When this movement constitutes a continuous translation in a fixed direction, such a hypersurface is called a *translator* to the flow. The mean curvature flow (MCF, for short), that is, the extrinsic flow determined by the mean curvature function, is certainly the most studied extrinsic flow. Indeed, there is a vast literature on MCF in Euclidean spaces and, in particular, on translators to MCF. In this context, it is well known that translators appear naturally as type II singularities (cf. [11]).

The rotationally symmetric translators to MCF in Euclidean space $\mathbb{R}^{n+1} = \mathbb{R}^n \times \mathbb{R}$ are completely classified. They constitute the entire graph obtained by Altschuler and Wu [1] known as the *bowl soliton* or *translating paraboloid*, and the one-parameter family of annuli obtained by Clutterbuck et al. [5] known as *translating catenoids* (see [2, Sect. 13.1] and the references therein for a detailed account on translators to MCF in Euclidean spaces).

Translators are naturally conceived in product spaces $M \times \mathbb{R}$, where M is a Riemannian manifold. On this matter, Bueno [3] managed to construct bowl-type and catenoid-type translators to MCF in $\mathbb{H}^2 \times \mathbb{R}$. Also, in [13], Lira and Martín considered translators to MCF in products $M \times \mathbb{R}$, where M is a Hadamard manifold endowed with a rotationally invariant metric. There, they constructed bowl-type and catenoid-type rotational translators, as well as translators which are invariant by either parabolic or hyperbolic horizontal translations of $M \times \mathbb{R}$. They also classified translators to MCF which are invariant by either rotations or translations. However, their list of translators having this property seems to be incomplete (cf. Remark 15 in Sect. 8). We add that, in [6], the first author proved the existence of graphical translators to flows by powers of the Gaussian curvature in $\mathbb{H}^n \times \mathbb{R}$ and $\mathbb{S}^n \times \mathbb{R}$, and that, in [15, 16], the second author classified all translators to MCF in the solvable group Sol_3 , as well as in Heisenberg group Nil_3 , which are invariant by some one-parameter group of ambient isometries.

In this paper, we consider translators to the extrinsic flows in $\mathbb{R}^n \times \mathbb{R}$ and $\mathbb{H}^n \times \mathbb{R}$ (called r -mean curvature flows or r -MCF, for short) whose velocity functions are the higher order mean curvatures H_r . Recall that the (nonnormalized) r -mean curvature of a hypersurface is the homogeneous polynomial of degree r of its principal curvatures, so that H_1 is the mean curvature and H_n is the Gaussian curvature.

More precisely, we address the problem of constructing and classifying translators to r -MCF which are invariant by either rotations or horizontal translations (Euclidean, parabolic or hyperbolic). We were motivated by the fact that r -mean curvature flows are particular examples of an importante and large class of fully nonlinear extrinsic flows (cf. [2, Chap. 18]). Yet, except for the cases $r = 1$ and $r = n$, such translators have never been considered, not even in Euclidean space.

We show that there exist rotational bowl-type and catenoid-type translators to r -MCF in both $\mathbb{R}^n \times \mathbb{R}$ and $\mathbb{H}^n \times \mathbb{R}$, and also that there exist parabolic and hyperbolic catenoid-type translators to r -MCF in $\mathbb{H}^n \times \mathbb{R}$. In addition, we show that there exist grim reaper-type translators to MCF and to Gaussian curvature flow (n -MCF) in $\mathbb{R}^n \times \mathbb{R}$ and $\mathbb{H}^n \times \mathbb{R}$.

Regarding our technique, we obtain the above r -translators by considering them as graphs whose level sets are parallel umbilical hypersurfaces of \mathbb{R}^n or \mathbb{H}^n . In this way, by imposing on these graphs the condition of being r -translators, we obtain ordinary

differential equations whose solutions yield the height functions of the r -translators we aim to construct. We add that these equations are nonlinear and, for $r > 1$, they are more involved than the ones for $r = 1$. Besides, for $r > 1$ odd, the catenoid-type translators to r -MCF have nonempty singular sets of null measure. We also remark that our method of using graphs built on parallel hypersurfaces is new in this theory. In fact, when applied to the case $r = 1$, it gives simpler proofs of the aforementioned existence results by Altschuler–Wu and Clutterbuck–Schnürer–Schulze, as well as the ones by Bueno.

We establish the uniqueness of the translators to r -MCF we obtain here, which we call *fundamental translators*, among those which are invariant by either rotations or translations. Then, we classify the translators to r -MCF whose r -th mean curvature is constant, as well as those which are isoparametric. We also characterize the non-cylindrical translators to MCF whose angle function is constant along their horizontal sections as those which are local graphs foliated by isoparametric hypersurfaces. In addition, we verify an interesting phenomenon; up to an ambient isometry, two distinct fundamental translators to r -MCF are asymptotic to each other, regardless the groups of isometries fixing them (cf. Remark 14 in Sect. 8).

We should mention that, at first, our intention was to consider r -translators in $\mathbb{S}^n \times \mathbb{R}$ as well. However, in this case, the associated differential equations behave quite differently from the ones we have when the ambient space is $\mathbb{R}^n \times \mathbb{R}$ or $\mathbb{H}^n \times \mathbb{R}$, making a unified treatment impossible. Hence, to avoid the paper becoming lengthy, we have chosen to consider r -translators in $\mathbb{S}^n \times \mathbb{R}$ in a forthcoming work.

The paper is organized as follows. In Sect. 2, we set some notation and introduce the notion of vertical graph in $\mathbb{R}^n \times \mathbb{R}$ and $\mathbb{H}^n \times \mathbb{R}$ whose level sets are parallel hypersurfaces. In Sect. 3, we discuss r -mean curvature flows in $\mathbb{R}^n \times \mathbb{R}$ and $\mathbb{H}^n \times \mathbb{R}$, establishing some fundamental results. In Sect. 4, we prove the existence of rotational bowl-type and catenoid-type translators to r -MCF in $\mathbb{R}^n \times \mathbb{R}$ and $\mathbb{H}^n \times \mathbb{R}$. The parabolic and hyperbolic versions of these results for translators in $\mathbb{H}^n \times \mathbb{R}$ are obtained in Sects. 5 and 6, respectively. In Sect. 7, we consider translators to Gaussian curvature flow, proving the existence of bowl-type and grim reaper-type ones. Finally, in Sect. 8, we establish the uniqueness results for fundamental translators we mentioned above.

2 Preliminaries

2.1 Isoparametric Hypersurfaces

Let \mathbb{M}^n be a Riemannian manifold. Given an open interval $I \subset \mathbb{R}$, one says that a one-parameter family

$$f_s: M^{n-1} \rightarrow \mathbb{M}^n, \quad s \in I,$$

of immersions is *parallel* if, for a fixed $s_0 \in I$, one has

$$f_s(p) := \exp_p(s\eta_{s_0}(p)), \quad p \in M, \quad s \in I, \quad (1)$$

where \exp is the exponential map of \mathbb{M}^n and η_{s_0} is the unit normal of f_{s_0} . In this setting, the hypersurfaces $M_s := f_s(M)$, $s \in I$, are also called *parallel*.

A family of parallel hypersurfaces

$$\{M_s \subset \mathbb{M}^n; s \in I \subset \mathbb{R}\}$$

of a Riemannian manifold \mathbb{M}^n is called *isoparametric* if each hypersurface M_s has constant mean curvature (possibly depending on s). If so, each hypersurface M_s is also called *isoparametric*. The isoparametric hypersurfaces of \mathbb{R}^n , as well as those of \mathbb{H}^n , are totally classified. Indeed, any such hypersurface is necessarily an open set of either a umbilical hypersurface or a tube over a totally geodesic submanifold of codimension greater than one (cf. [4, Theorems 3.12 and 3.14]).

2.2 Hypersurfaces of $\mathbb{Q}_\epsilon^n \times \mathbb{R}$

We shall consider oriented hypersurfaces in the product $\mathbb{Q}_\epsilon^n \times \mathbb{R}$ endowed with its standard product metric, where \mathbb{Q}_ϵ^n denotes the simply connected space form of constant sectional curvature $\epsilon \in \{0, -1\}$, i.e., Euclidean space \mathbb{R}^n or hyperbolic space \mathbb{H}^n .

Given an oriented hypersurface Σ of $\mathbb{Q}_\epsilon^n \times \mathbb{R}$, set N for its unit normal field and A for its shape operator with respect to N , so that

$$AX = -\bar{\nabla}_X N, \quad X \in T\Sigma,$$

where $\bar{\nabla}$ is the Levi-Civita connection of $\mathbb{Q}_\epsilon^n \times \mathbb{R}$, and $T\Sigma$ is the tangent bundle of Σ . The principal curvatures of Σ , that is, the eigenvalues of the shape operator A , will be denoted by k_1, \dots, k_n .

We define the *height function* ϕ and the *angle function* Θ of Σ as:

$$\phi := \pi_{\mathbb{R}}|_{\Sigma} \quad \text{and} \quad \Theta := \langle N, \partial_t \rangle,$$

where ∂_t denotes the gradient of the projection $\pi_{\mathbb{R}}$ of $\mathbb{Q}_\epsilon^n \times \mathbb{R}$ on its second factor \mathbb{R} . Notice that ∂_t is a parallel field on $\mathbb{Q}_\epsilon^n \times \mathbb{R}$. So, denoting by ∇ the gradient on $C^\infty(\Sigma)$ and writing $T := \nabla\phi$, we have that the identities

$$T = \partial_t - \Theta N \quad \text{and} \quad AT = -\nabla\Theta \tag{2}$$

hold everywhere on Σ . From the first of them, one has:

$$\|T\|^2 = 1 - \Theta^2.$$

Given an integer $r \in \{1, \dots, n\}$, recall that the (non normalized) r -th *mean curvature* H_r of a hypersurface Σ of $\mathbb{Q}_\epsilon^n \times \mathbb{R}$ is the function:

$$H_r := \sum_{i_1 < \dots < i_r} k_{i_1} \dots k_{i_r}.$$

Notice that H_1 and H_n are the non normalized mean curvature and the Gaussian curvature of Σ , respectively.

2.3 Graphs on Parallel Hypersurfaces

Let $\mathcal{F} := \{M_s \subset \mathbb{Q}_\epsilon^n; s \in I\}$ be a family of parallel hypersurfaces of \mathbb{Q}_ϵ^n , where $I \subset \mathbb{R}$ is an open interval. Given a smooth function ϕ on I , let

$$f: M_{s_0} \times I \rightarrow \mathbb{Q}_\epsilon^n \times \mathbb{R}, \quad s_0 \in I,$$

be the immersion given by

$$f(p, s) := (\exp_p(s\eta_{s_0}(p)), \phi(s)), \quad (p, s) \in M_{s_0} \times I, \tag{3}$$

where \exp denotes the exponential map of \mathbb{Q}_ϵ^n , and η_{s_0} is the unit normal of M_{s_0} . The hypersurface $\Sigma = f(M_{s_0} \times I)$ is a vertical graph over an open set of \mathbb{Q}_ϵ^n whose level hypersurfaces are the parallels M_s to M_{s_0} .

Definition 1 With the above notation, we shall call Σ an (M_s, ϕ) -graph.

As proved in [8], the unit normal N of Σ (when endowed with the metric induced by f) at a point $(p, s) \in M_{s_0} \times I$ is

$$N = -\varrho(s)\eta_s(p) + \Theta \partial_t, \tag{4}$$

where ϱ is the function defined by

$$\varrho := \frac{\phi'}{\sqrt{1 + (\phi')^2}} \left(\Leftrightarrow \phi' = \frac{\varrho(s)}{\sqrt{1 - \varrho^2(s)}} \right), \tag{5}$$

and Θ is the angle function of Σ . With this orientation, the principal curvatures $k_i = k_i(p, s)$ of an (M_s, ϕ) -graph Σ at a point $(p, s) \in M_{s_0} \times I$ are:

$$k_i = -\varrho(s)k_i^s(p), \quad i = 1, \dots, n - 1, \quad \text{and} \quad k_n = \varrho'(s), \tag{6}$$

where $k_i^s(p)$ is the principal curvature function of the parallel M_s at $\exp_p(s\eta_{s_0}(p))$, $p \in M_{s_0}$.

By integrating (5), we conclude that ϱ determines the height function ϕ up to a constant. More precisely:

$$\phi(s) = \int_{s_0}^s \frac{\varrho(u)}{\sqrt{1 - \varrho^2(u)}} du + \phi(s_0), \quad s_0, s \in I. \tag{7}$$

It can also be proved that the equality

$$\varrho^2 + \Theta^2 = 1 \tag{8}$$

Table 1 Definition of \cos_ϵ and \sin_ϵ

Function	$\epsilon = 0$	$\epsilon = -1$
$\cos_\epsilon(s)$	1	$\cosh s$
$\sin_\epsilon(s)$	s	$\sinh s$

Table 2 Principal curvatures of the umbilical hypersurfaces of \mathbb{Q}_ϵ^n

Hypersurface M_s	Principal curvatures ($i = 1, \dots, n - 1$)
$\mathbb{Q}_\epsilon^{n-1}$	$k_i^s = 0$
S_s^{n-1}	$k_i^s = -\cot_\epsilon(s)$
\mathcal{H}^{n-1}	$k_i^s = -1$
\mathcal{E}^{n-1}	$k_i^s = -\tanh(s)$

holds everywhere on Σ (see Sect. 3 of [8] for details and proofs).

From equalities (5) and (8), we have the following relation between ϕ' and Θ :

$$\Theta^2 = \frac{1}{1 + (\phi')^2}. \tag{9}$$

2.4 Umbilical Hypersurfaces of \mathbb{Q}_ϵ^n

The (M_s, ϕ) -graphs we shall consider here are those whose parallel level hypersurfaces are umbilical. Recall that the umbilical hypersurfaces of \mathbb{Q}_ϵ^n are:

- The totally geodesic hyperplanes $\mathbb{Q}_\epsilon^{n-1} \subset \mathbb{Q}_\epsilon^n$.
- The geodesic spheres $S_s^{n-1} \subset \mathbb{Q}_\epsilon^n$ of radius $s > 0$.
- The horospheres \mathcal{H}^{n-1} of \mathbb{H}^n .
- The equidistant hypersurfaces \mathcal{E}^{n-1} to totally geodesic hyperplanes of \mathbb{H}^n .

Defining \cos_ϵ and \sin_ϵ as in Table 1, and setting

$$\tan_\epsilon = \frac{\sin_\epsilon}{\cos_\epsilon} \quad \text{and} \quad \cot_\epsilon = \frac{1}{\tan_\epsilon},$$

we have that the principal curvatures of the umbilical hypersurfaces of \mathbb{Q}_ϵ^n (endowed with the outward orientation) are as indicated in Table 2.

2.5 Invariant Hypersurfaces of $\mathbb{Q}_\epsilon^n \times \mathbb{R}$

In hyperbolic space \mathbb{H}^n , there are three special types of one-parameter families of isometries. They are the rotations around a fixed point (*elliptic isometries*), the translations along horocycles sharing the same point at infinity (*parabolic isometries*), and the translations along a fixed geodesic (*hyperbolic isometries*). In Euclidean space, the one-parameter groups of rotations, as well as of translations in a fixed direction, are well known.

Observe that each one of the aforementioned groups of isometries of \mathbb{Q}_ϵ^n fixes a family of umbilical hypersurfaces. Indeed, an elliptic isometry fixes a family of parallel spheres, whereas a parabolic (resp. hyperbolic) translation fixes a family of parallel horospheres (resp. equidistant hypersurfaces). A translation in a fixed direction in \mathbb{R}^n fixes a family of parallel hyperplanes.

These isometries of \mathbb{Q}_ϵ^n extend naturally to isometries of $\mathbb{Q}_\epsilon^n \times \mathbb{R}$ (which we call *horizontal*) by fixing the factor \mathbb{R} pointwise. Therefore, a hypersurface $\Sigma \subset \mathbb{Q}_\epsilon^n \times \mathbb{R}$ which is invariant by such a group of isometries is necessarily foliated by vertical translations of its corresponding family of umbilical hypersurfaces. We shall call such a Σ an *invariant* hypersurface of $\mathbb{Q}_\epsilon^n \times \mathbb{R}$. An invariant hypersurface of $\mathbb{H}^n \times \mathbb{R}$ will be called *parabolic* (resp. *hyperbolic*) if it is invariant by horizontal parabolic translations (resp. hyperbolic translations).

3 Translators to the r -th Mean Curvature Flow

Given positive integers $n \geq 2$ and $r \in \{1, \dots, n\}$, we say that an oriented hypersurface Σ of $\mathbb{Q}_\epsilon^n \times \mathbb{R}$ moves under H_r -flow if there exists a one-parameter family of immersions $F: \Sigma_0 \times [0, u_0) \rightarrow \mathbb{Q}_\epsilon^n \times \mathbb{R}$, $u_0 \leq +\infty$, such that

$$\begin{cases} \frac{\partial F}{\partial u}^\perp(p, u) = H_r(p, u)N(p, u). \\ F(\Sigma_0, 0) = \Sigma, \end{cases} \tag{10}$$

where $N(p, u)$ is the inward unit normal to the hypersurface $F_u := F(\cdot, u)$, $H_r(p, u)$ is the r -th mean curvature of F_u with respect to $N_u := N(\cdot, u)$, and $\frac{\partial F}{\partial u}^\perp$ denotes the normal component of $\frac{\partial F}{\partial u}$, i.e.,

$$\frac{\partial F}{\partial u}^\perp = \left\langle \frac{\partial F}{\partial u}, N_u \right\rangle N_u.$$

In particular, the first equality in (10) is equivalent to

$$\left\langle \frac{\partial F}{\partial u}(p, u), N(p, u) \right\rangle = H_r(p, u). \tag{11}$$

We call such a map F an H_r -flow in $\mathbb{Q}_\epsilon^n \times \mathbb{R}$.

Denote by \exp the exponential map of $\mathbb{Q}_\epsilon^n \times \mathbb{R}$ and consider an isometric immersion $F_0: \Sigma_0 \rightarrow \mathbb{Q}_\epsilon^n \times \mathbb{R}$. Define then the map

$$F(p, u) := \exp_{F_0(p)}(u\partial_t), \quad (p, u) \in \Sigma_0 \times [0, +\infty),$$

and notice that, for each $u \in (0, +\infty)$, the hypersurface $F(\Sigma_0, u)$ is nothing but an upwards vertical translation of $\Sigma := F(\Sigma_0, 0)$. Since vertical translations are isometries of $\mathbb{Q}_\epsilon^n \times \mathbb{R}$, we have that Σ and $F(\Sigma_0, u)$ are congruent, so that their angle

functions and r -th mean curvature functions coincide, that is,

$$\Theta(p, u) = \Theta(p, 0) \quad \text{and} \quad H_r(p, u) = H_r(p, 0) \quad \forall (p, u) \in \Sigma_0 \times [0, u_0). \quad (12)$$

Now, differentiating F with respect to u , we have

$$\frac{\partial F}{\partial u}(p, u) = (d \exp_{F_0(p)})(u \partial_t) \partial_t = \partial_t. \quad (13)$$

From (12) and (13), we have that F satisfies (11) if and only if the equality

$$\Theta(p, 0) = H_r(p, 0)$$

holds for all $p \in \Sigma_0$. This fact motivates the following concept.

Definition 2 Given positive integers $n \geq 2$ and $r \in \{1, \dots, n\}$, we say that a hypersurface Σ of $\mathbb{Q}_\epsilon^n \times \mathbb{R}$ is a *translator* (or a *translating soliton*) to the r -th mean curvature flow (r -MCF, for short), if the equality $H_r = \Theta$ holds everywhere on Σ . We shall also call a translator to r -MCF an r -*translator*.

Example 1 Let $\mathbb{Q}_\epsilon^{n-1} \subset \mathbb{Q}_\epsilon^n$ be a totally geodesic hyperplane of \mathbb{Q}_ϵ^n . Then, $\Sigma = \mathbb{Q}_\epsilon^{n-1} \times \mathbb{R}$ is a totally geodesic hypersurface of $\mathbb{Q}_\epsilon^n \times \mathbb{R}$ which we call a *vertical hyperplane*. On such a Σ , $H_r = \Theta = 0$, which implies that Σ is an r -translator for all $r \in \{1, \dots, n\}$. In addition, from the first equality in (10), Σ is stationary under r -MCF. More generally, if $\Gamma \subset \mathbb{Q}_\epsilon^n$ is an r -minimal hypersurface for some $r \in \{1, \dots, n - 1\}$ (i.e., the r -th mean curvature of Γ vanishes everywhere), then the cylinder $\Gamma \times \mathbb{R}$ is a stationary translator to r -MCF in $\mathbb{Q}_\epsilon^n \times \mathbb{R}$. The same holds for $r = n$ if Γ is any hypersurface of \mathbb{Q}_ϵ^n .

Remark 1 We shall consider n -submanifolds Σ of $\mathbb{Q}_\epsilon^n \times \mathbb{R}$ which are of class at least C^2 , except on a set of null measure $\Lambda \subset \Sigma$, where Σ is of class C^1 . In this case, we shall say that Σ is C^2 -singular on Λ . If the equality $H_r = \Theta$ holds on $\Sigma - \Lambda$, by abuse of terminology, we still call Σ an r -translator (see Remark 4 in Sect. 4). We add that, in a similar fashion, some rotational hypersurfaces of constant r -th mean curvature constructed in [14] have C^2 -singular sets.

Remark 2 Setting $\mathbf{k} := (k_1, \dots, k_n)$, it is easily seen that the r -th mean curvature function H_r satisfies $H_r(-\mathbf{k}) = -H_r(\mathbf{k})$ when r is odd. In this case, given an orientable hypersurface $\Sigma \subset \mathbb{Q}_\epsilon^n \times \mathbb{R}$ and a unit normal field N on Σ , the r -mean curvature vector $\mathbf{H}_r := H_r N$ is well defined, that is, it is independent of the orientation N , and so we can write (10) as

$$\begin{cases} \frac{\partial F}{\partial u}^\perp(p, u) = \mathbf{H}_r(p, u), \\ F(\Sigma_0, 0) = \Sigma. \end{cases}$$

On the other hand, for r even, one has

$$H_r(-\mathbf{k}) = H_r(\mathbf{k}), \quad (14)$$

so that the r -mean curvature vector is not defined.

Remark 3 Let Φ be the reflection over a horizontal hyperplane $\Pi_t := \mathbb{Q}_\epsilon^n \times \{t\}$ in $\mathbb{Q}_\epsilon^n \times \mathbb{R}$. Suppose that Σ is an r -translator in $\mathbb{Q}_\epsilon^n \times \mathbb{R}$ with unit normal N , and call $\bar{\Sigma}$ the hypersurface $\Phi(\Sigma)$ with unit normal $\bar{N} \circ \Phi := -\Phi_*N$. Then, if r is even, $\bar{\Sigma}$ is an r -translator as well. Indeed, in this case, we have from (14) that the r -mean curvature function is invariant by change of orientation. This, together with the fact that Φ is an isometry, gives that the r -mean curvature H_r of Σ at a point p coincides with the r -mean curvature \bar{H}_r of $\bar{\Sigma}$ at $\Phi(p)$. Therefore,

$$\bar{H}_r \circ \Phi = H_r = \langle N, \partial_t \rangle = \langle \Phi_*N, \Phi_*\partial_t \rangle = \langle \bar{N} \circ \Phi, \partial_t \rangle,$$

which gives that $\bar{\Sigma}$ is an r -translator.

3.1 Graphs on Parallels as Translators

Let $\{M_s; s \in I\}$ be a family of parallel umbilical hypersurfaces of \mathbb{Q}_ϵ^n . With the notation as in Table 2, set

$$\alpha(s) = -k_i^s, \quad i = 1, \dots, n - 1. \tag{15}$$

Considering the identities (6) and writing

$$H_r = \sum_{i_1 < \dots < i_r \neq n} k_{i_1} \dots k_{i_r} + \sum_{i_1 < \dots < i_{r-1}} k_{i_1} \dots k_{i_{r-1}} k_n,$$

we have that the r -th mean curvature of an (M_s, ϕ) -graph Σ is a function of s alone which is given by

$$H_r = \binom{n-1}{r} (\alpha \varrho)^r + \binom{n-1}{r-1} (\alpha \varrho)^{r-1} \varrho'.$$

This last equality, together with (8), gives the following result.

Proposition 1 *Let $\{M_s; s \in I\}$ be a family of parallel umbilical hypersurfaces of \mathbb{Q}_ϵ^n , and let α be as in (15). Then, an (M_s, ϕ) -graph Σ in $\mathbb{Q}_\epsilon^n \times \mathbb{R}$ is an r -translator if and only if its associated ϱ -function satisfies:*

$$\binom{n-1}{r} (\alpha \varrho)^r + \binom{n-1}{r-1} (\alpha \varrho)^{r-1} \varrho' = \sqrt{1 - \varrho^2}. \tag{16}$$

As a first application of Proposition 1, we shall recover a classical translator to MCF in Euclidean space.

Example 2 (grim reaper) Let $\mathcal{F} := \{M_s; s \in \mathbb{R}\}$ be a family of parallel totally geodesic hyperplanes in \mathbb{R}^n . Then, considering Proposition 1 for $\epsilon = 0$, $r = 1$, and \mathcal{F} ,

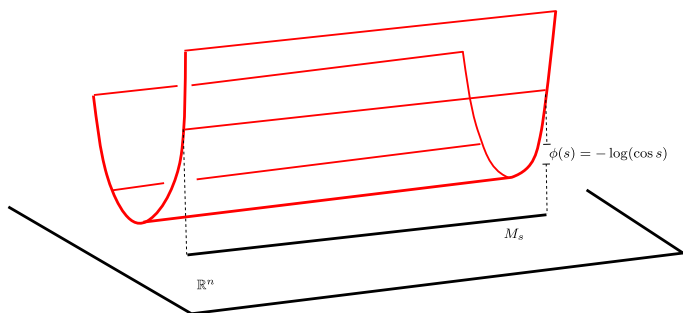

Fig. 1 The grim reaper

one has that (16) becomes $q' = \sqrt{1 - q^2}$, which gives $q(s) = \sin(s)$. Consequently, the height function of the corresponding (M_s, ϕ) -graph Σ is (assuming $\phi(0) = 0$):

$$\phi(s) = \int_0^s \frac{q(u)}{\sqrt{1 - q^2(u)}} du = \int_0^s \tan(u) du = -\log(\cos s), \quad s \in (-\pi/2, \pi/2),$$

so that Σ is the solution to MCF in $\mathbb{R}^n \times \mathbb{R}$ known as the *grim reaper* (Fig. 1).

Notice that, for $r > 1$, (16) reduces to $\sqrt{1 - q^2} = 0$, giving that $q(s) = 1$ for all $s \in (-\infty, +\infty)$. In this case, the corresponding (M_s, ϕ) -graph degenerates into a vertical totally geodesic hyperplane of $\mathbb{R}^n \times \mathbb{R}$ (see Example 1).

Considering the above example, we shall exclude the families of parallel hyperplanes of \mathbb{R}^n in the discussion that follows, i.e., the function α will be \cot_ϵ , \tanh or the constant 1 (cf. Table 2). Under this hypothesis, setting $\tau = q^r$, the ODE (16) assumes the form

$$\tau'(s) = C(\alpha(s))^{1-r} \sqrt{1 - \tau^{2/r}(s)} - (n - r)\alpha(s)\tau(s), \tag{17}$$

where $C = C(n, r) = r \binom{n-1}{r-1}^{-1}$. This equality suggests the consideration of the following Cauchy problem:

$$\begin{cases} y'(s) = F(s, y(s)) \\ y(s_0) = y_0, \end{cases} \tag{18}$$

where $(s_0, y_0) \in \Omega := (0, +\infty) \times [-1, 1]$ and $F = F_{(n,r,\alpha)}$ is the function

$$F(s, y) := C(\alpha(s))^{1-r} \sqrt{1 - y^{2/r}} - (n - r)\alpha(s)y, \quad (s, y) \in \Omega. \tag{19}$$

Since F is C^∞ in the interior of Ω , the orbits of the slope field determined by F constitute a foliation of Ω by the graphs of the solutions of (18). Consequently, the endpoints of such graphs are necessarily boundary points of Ω .

In what follows, we establish the qualitative behavior of the solutions to (18) as suggested in Fig. 2. We shall consider first the case $r < n$. The case $r = n$ will be

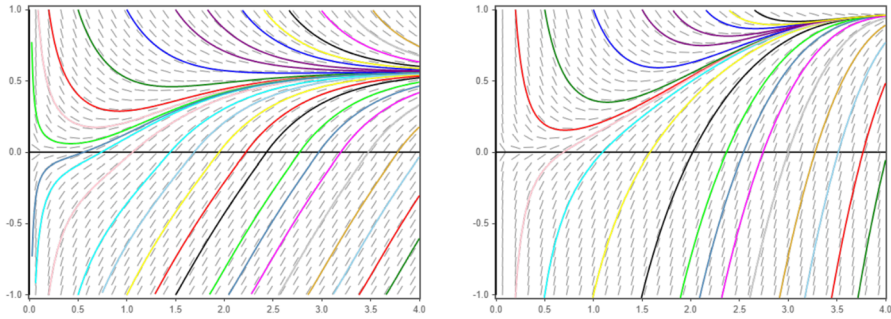

Fig. 2 Graphs of solutions to (18) for $(n, r, \alpha) = (4, 3, \text{coth})$ (left) and $(n, r, \alpha) = (4, 2, \text{cot}_0)$ (right)

treated in Sect. 7.

Definition 3 Given integers $\epsilon \in \{0, -1\}$, $n \geq 2$, and $r \in \{1, \dots, n\}$, define the *limit constant* $L = L(\epsilon, n, r) \in (0, 1]$ as the only positive number satisfying

$$C\sqrt{1 - L^{2/r}} + \epsilon(n - r)L = 0, \quad C = C(n, r) = r \binom{n - 1}{r - 1}^{-1},$$

and the *limit angle* $\Theta_L \in [0, 1)$ as

$$\Theta_L := \sqrt{1 - L^{2/r}}.$$

In particular, $L = 1$ (and $\Theta_L = 0$) if and only if $\epsilon = 0$ or $n = r$.

Proposition 2 Let $r \in \{1, \dots, n - 1\}$. Given $s_0 > 0$, denote by $\tau_{s_0}^-$ and $\tau_{s_0}^+$ the solutions of (18) for $y_0 = -1$ and $y_0 = 1$, respectively. Then, $\tau_{s_0}^\pm$ are both defined in $[s_0, +\infty)$ and have the following properties:

- (i) $\tau_{s_0}^-$ has one and only one zero $s_1 \in (s_0, +\infty)$, and its derivative is positive if the function α is either cot_ϵ or 1. For $\alpha = \text{tanh}$, $\tau_{s_0}^-$ has at most one critical point $s_* > s_1$, which is necessarily a maximum.
- (ii) $\tau_{s_0}^+$ is positive in $[s_0, +\infty)$ and has at most one critical point, which is necessarily a minimum.

In addition, the following equalities hold:

$$\lim_{s \rightarrow +\infty} \tau_{s_0}^-(s) = \lim_{s \rightarrow +\infty} \tau_{s_0}^+(s) = L, \tag{20}$$

where L is the limit constant (cf. Definition 3).

Proof From the hypothesis, $\tau_{s_0}^-$ satisfies (17) and $\tau_{s_0}^-(s_0) = -1$. Hence,

$$(\tau_{s_0}^-)'(s_0) = (n - r)\alpha(s_0) > 0,$$

which implies that $\tau_{s_0}^-$ is strictly increasing near s_0 . It is clear from (17) that $\tau_{s_0}^-$ will be strictly increasing as long as it stays negative. So, we have two possibilities, $\tau_{s_0}^-$ vanishes at some point $s_1 > s_0$, or it is defined in $[s_0, +\infty)$, being negative and strictly increasing in this interval. Assuming the latter, we have that the graph of $\tau_{s_0}^-$ has a horizontal asymptotic line, so that

$$\lim_{s \rightarrow +\infty} (\tau_{s_0}^-)'(s) = 0.$$

However, from (17) and the properties of α , we also have

$$0 < \lim_{s \rightarrow +\infty} (\tau_{s_0}^-)'(s) < +\infty,$$

which is clearly a contradiction. Hence, $\tau_{s_0}^-(s_1) = 0$ for some $s_1 > s_0$.

Considering (17), we see that $(\tau_{s_0}^-)'(s) > 0$ for all s such $\tau_{s_0}^-(s) = 0$, from which we conclude that s_1 is the only zero of $\tau_{s_0}^-$. Moreover, since $F(s, 1) < 0$ for all $s > 0$ (F as in (19)), we have that there is no $s \in (s_0, +\infty)$ such that $\tau_{s_0}^-(s) = 1$, which implies that $\tau_{s_0}^-$ is defined in $[s_0, +\infty)$.

We claim that $\tau_{s_0}^-$ has at most one critical point. Indeed, by the above considerations, any critical point s_* of $\tau_{s_0}^-$ is necessarily larger than s_1 . In particular, $\tau_{s_0}^-(s_*) > 0$.

Let us consider first the case $\alpha = 1$. Then, we have

$$F(s, y) = C\sqrt{1 - y^{2/r}} - (n - r)y,$$

which implies that the constant function $\tau_L(s) = L$ is a solution to (18) satisfying $y(s_0) = L$, where L is the limit constant. If there is $s_* > s_1$ such that $(\tau_{s_0}^-)'(s_*) = 0$, then $F(s_*, \tau_{s_0}^-(s_*)) = 0$, which yields $\tau_{s_0}^-(s_*) = L$. Thus, by uniqueness of solutions, we have that $\tau_{s_0}^-$ coincides with the constant function τ_L on $[s_0, +\infty)$, which is clearly an absurd. Therefore, $\tau_{s_0}^-$ has no critical points if $\alpha = 1$. In particular, $(\tau_{s_0}^-)' > 0$ in $[s_0, +\infty)$.

Now, let α be either \cot_ϵ or \tanh , and assume that $s_* > s_1$ is a critical point of $\tau_{s_0}^-$. In this setting, we have from (17) that

$$(\tau_{s_0}^-)''(s_*) = -\alpha'(s_*)[C(r - 1)(\alpha(s_*))^{-r}\sqrt{1 - \tau_{s_0}^{2/r}(s_*)} + (n - r)\tau(s_*)]. \tag{21}$$

Since the derivatives of \cot_ϵ and \tanh are negative and positive in $(0, +\infty)$, respectively, we have from (21) that $(\tau_{s_0}^-)''(s_*)$ is positive if $\alpha = \cot_\epsilon$ (so that s_* is a local minimum) and negative if $\alpha = \tanh$ (so that s_* is a local maximum). In any of these cases, s_* is the only possible critical point of $(\tau_{s_0}^-)$, proving our claim. However, $\tau_{s_0}^-$ is strictly increasing in a neighborhood of s_1 , so that its smaller critical point could not be a local minimum. Hence, for $\alpha = \cot_\epsilon$, $\tau_{s_0}^-$ has no critical points, that is, $(\tau_{s_0}^-)' > 0$ in $[s_0, +\infty)$.

It follows from the above considerations that, for any $s_0 > 0$,

$$L_{s_0}^- := \lim_{s \rightarrow +\infty} \tau_{s_0}^-(s) \tag{22}$$

is well defined and satisfies $0 < L_{s_0}^- \leq 1$, which implies that $(\tau_{s_0}^-)'(s) \rightarrow 0$ as $s \rightarrow +\infty$. Therefore,

$$\lim_{s \rightarrow +\infty} F(s, \tau_{s_0}^-(s)) = 0. \tag{23}$$

We have that, as $s \rightarrow +\infty$, $\alpha(s) \rightarrow -\epsilon$ (resp. $\alpha(s) \rightarrow 1$) if $\alpha = \cot_\epsilon$ (resp. $\alpha = 1$ or $\alpha = \tanh$). In any of these cases, it follows from (23) that

$$C\sqrt{1 - (L_{s_0}^-)^{2/r}} + \epsilon(n - r)L_{s_0}^- = 0,$$

which implies that $L_{s_0}^- = L$.

Regarding $\tau_{s_0}^+$, we have from (17) that $(\tau_{s_0}^+)'(s_0) = -(n - r)\alpha(s_0) < 0$, giving that $\tau_{s_0}^+$ is decreasing near s_0 . Also, as we have seen, the graph of a solution to (18) cannot cross the s -axis from the positive side, so that $\tau_{s_0}^+$ is positive. From this point, reasoning as in the preceding paragraphs, one concludes that $\tau_{s_0}^+$ is defined in $[s_0, +\infty)$ and has at most one critical point in this interval, which is necessarily a minimum. Therefore, the number

$$L_{s_0}^+ := \lim_{s \rightarrow +\infty} \tau_{s_0}^+(s) \tag{24}$$

is well defined and satisfies $0 < L_{s_0}^+ \leq 1$. As it was for $L_{s_0}^-$, this last equality yields $L_{s_0}^+ = L$. This finishes the proof. \square

4 Rotational Translators to $r(<n)$ -MCF

This section concerns $r(<n)$ -translators in $\mathbb{Q}_\epsilon^n \times \mathbb{R}$ which are invariant by rotations. More precisely, such a translator will be considered as an (M_s, ϕ) -graph Σ , where $\{M_s = S_s^{n-1}; s \in I \subset (0, +\infty)\}$ is a family of concentric geodesic spheres of \mathbb{Q}_ϵ^n centered at a point $o \in \mathbb{Q}_\epsilon^n$.

In this setting, with the notation of the preceding section, we have $\alpha = \cot_\epsilon$, so that equation (17) becomes

$$\tau'(s) = C\sqrt{1 - \tau^{2/r}(s)} \tan_\epsilon^{r-1}(s) - (n - r) \cot_\epsilon(s)\tau(s), \tag{25}$$

and the Cauchy problem (18) becomes

$$\begin{cases} y'(s) = F(s, y(s)) \\ y(s_0) = y_0, \end{cases} \tag{26}$$

where $(s_0, y_0) \in \Omega := (0, +\infty) \times [-1, 1]$, and $F = F_{(\epsilon, n, r)}$ is the function:

$$F(s, y) := C\sqrt{1 - y^{2/r}} \tan_\epsilon^{r-1}(s) - (n - r) \cot_\epsilon(s)y, \quad 1 \leq r < n, \quad (s, y) \in \Omega \tag{27}$$

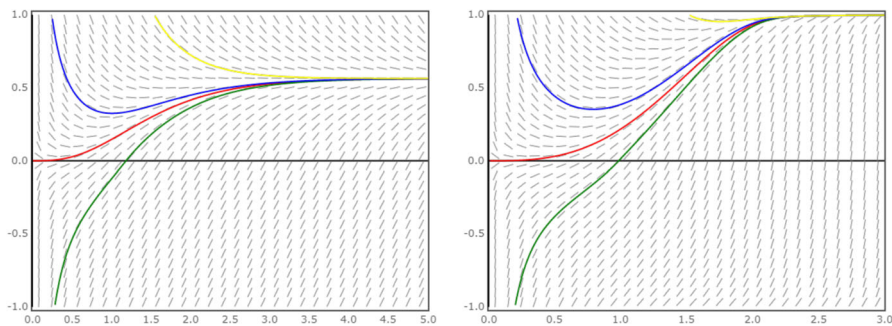

Fig. 3 Orbits of the slope field of $F_{(\epsilon,n,r)}$ for $(\epsilon, n, r) = (-1, 4, 3)$ (left), and $(\epsilon, n, r) = (0, 4, 3)$ (right)

In the next propositions we establish that, besides the solutions $\tau_{s_0}^\pm$ defined in Proposition 2, the Cauchy problem (26) has a solution τ_0 defined in $[0, +\infty)$ which satisfies $\tau_0(0) = 0$. Moreover, the functions τ_0 and $\tau_{s_0}^\pm$ are the only solutions to (18) defined in a maximal interval (Fig. 3).

Proposition 3 *Given $s_0 > 0$, let $\tau_{s_0}^-$, $\tau_{s_0}^+$, and $L \in (0, 1]$ be as in Proposition 2. Then, there exists a solution $\tau_0 : [0, +\infty) \rightarrow [0, L)$ of (26) such that:*

- (i) $\tau_0(0) = 0$.
- (ii) τ_0 and τ_0' are both positive in $(0, +\infty)$.
- (iii) $\lim_{s \rightarrow +\infty} \tau_0(s) = L$.
- (iv) For any $s_0 > 0$, the inequalities $\tau_{s_0}^- < \tau_0 < \tau_{s_0}^+$ hold on $[s_0, +\infty)$.

Proof Given $s_1 > 0$, let τ_{s_1} be the solution to (26) satisfying the initial condition $\tau_{s_1}(s_1) = 0$. Proceeding as in the proof of Proposition 2, we conclude that τ_{s_1} is defined in $[s_1, +\infty)$, is strictly increasing, and satisfies

$$\lim_{s \rightarrow +\infty} \tau_{s_1}(s) = L.$$

Now, define the function ψ_{s_1} on $(0, +\infty)$ by

$$\psi_{s_1}(s) := \tau_{s_1}(s_1 + s).$$

For any $s_1 > 0$, ψ_{s_1} is strictly increasing with lowest upper bound L . Hence, as $s_1 \rightarrow 0$, the functions ψ_{s_1} converge uniformly to the function $\tau_0 : (0, +\infty) \rightarrow (0, L)$ given by

$$\tau_0(s) := \lim_{s_1 \rightarrow 0} \psi_{s_1}(s).$$

In addition, one has

$$\psi'_{s_1}(s) = \tau'_{s_1}(s_1 + s) = F(s_1 + s, \tau_{s_1}(s_1 + s)) = F(s_1 + s, \psi_{s_1}(s)),$$

which implies that, as $s_1 \rightarrow 0$, the derivatives ψ'_{s_1} converge uniformly to the function $s \mapsto F(s, \tau_0(s))$ in any compact interval $[a, b] \subset (0, +\infty)$. Therefore, τ_0 is differentiable in $(0, +\infty)$ and satisfies (cf. [10, Theorem 4.7.8])

$$\tau'_0(s) = \lim_{s_1 \rightarrow 0} \psi'_{s_1}(s) = \lim_{s_1 \rightarrow 0} F(s_1 + s, \psi_{s_1}(s)) = F(s, \tau_0(s)),$$

so that τ_0 is a solution to (26) on $(0, +\infty)$. Besides, it is easily checked that τ_0 extends smoothly to $s = 0$ and satisfies

$$\tau_0(0) = 0 \quad \text{and} \quad \tau'_0(0) = \begin{cases} 1 & \text{if } r = 1, \\ 0 & \text{if } 1 < r \leq n - 1. \end{cases}$$

The proofs of (ii) and (iii) are analogous to the ones given in Proposition 2 for the functions τ_{s_0} . Finally, denoting by $\mathcal{G}_0, \mathcal{G}_{s_0}^-$, and $\mathcal{G}_{s_0}^+$ the graphs of $\tau_0, \tau_{s_0}^-$, and $\tau_{s_0}^+$, respectively, we have that \mathcal{G}_0 separates Ω into two connected components, one below \mathcal{G}_0 , say Ω^- , and one above \mathcal{G}_0 , Ω^+ . By the uniqueness of solutions to (26) with given initial conditions, the graphs of two distinct solutions never intersect. Hence, for any $s_0 > 0$, one has $\mathcal{G}_{s_0}^- \subset \Omega^-$ and $\mathcal{G}_{s_0}^+ \subset \Omega^+$. This clearly implies (iv) and finishes our proof. \square

Proposition 4 *Let τ_0 be as in Proposition 3. Then, for $\varrho_0 = \tau_0^{1/r}$, one has that the limits*

$$L_1 := \lim_{s \rightarrow 0} (\cot_\epsilon(s) \varrho_0(s)) \quad \text{and} \quad L_2 := \lim_{s \rightarrow 0} \varrho'_0(s)$$

are both finite.

Proof Since τ_0 is a solution to (25), we have that (16) holds for $\alpha = \cot_\epsilon$ and $\varrho = \varrho_0$. Hence, L_1 and L_2 cannot be both infinite, for $\sqrt{1 - \varrho_0^2(s)} \rightarrow 1$ as $s \rightarrow 0$. In addition,

$$\lim_{s \rightarrow 0} (\cot_\epsilon(s) \varrho_0(s)) = \lim_{s \rightarrow 0} \left(\frac{\varrho_0(s)}{\tan_\epsilon(s)} \right) = \lim_{s \rightarrow 0} (\varrho'_0(s) \cos_\epsilon^2(s)),$$

which clearly implies that L_1 and L_2 are both finite. \square

Proposition 5 *The only solutions to the Cauchy problem (26) which are defined in a maximal interval are the functions $\tau_{s_0}^\pm$ of Proposition 2, and the function τ_0 of Proposition 3.*

Proof It suffices to prove that there is no solution to (26) whose graph has an endpoint of the form $p := (0, b)$ with $b \neq 0$. Assume, by contradiction, that such a solution exists and call it τ . Assuming also that $b > 0$, we have that $F(s, b) \rightarrow -\infty$ as $s \rightarrow 0$. Then, if we extend τ to 0 by making $\tau(0) = b$, the graph \mathcal{G} of τ is tangent to the y -axis at p (Fig. 4).

Now, choose a small $c > 0$ such that $\tau' < 0$ on $(0, c)$, and set $a := \tau(c) > 0$. Given a positive $\delta < c$, let \mathcal{S}_δ be the line segment from $p = (0, b)$ to (δ, a) . It is clear that

Fig. 4 Graph \mathcal{G} of the function τ considered in the proof of Proposition 5

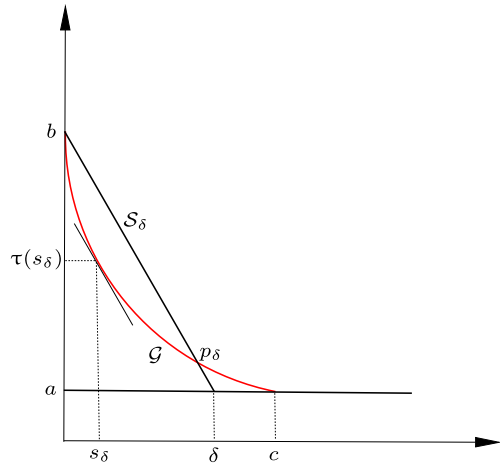

\mathcal{S}_δ intersects \mathcal{G} at a single point p_δ . Then, by Rolle’s Theorem, there exists a point $q_\delta := (s_\delta, \tau(s_\delta))$ in the open arc of \mathcal{G} from p to p_δ such that the tangent line to \mathcal{G} at q_δ is parallel to \mathcal{S}_δ . In particular, $\tau'(s_\delta) = -(b - a)/\delta$. Thus, by (25),

$$-C\sqrt{1 - \tau^{2/r}(s_\delta)} \tan_\epsilon^{r-1}(s_\delta) + (n - r) \cot_\epsilon(s_\delta)\tau(s_\delta) = \frac{b - a}{\delta}.$$

Since $0 < s_\delta < \delta$, we have that $\delta \cot_\epsilon(s_\delta) > s_\delta \cot_\epsilon(s_\delta) \geq 1$. This, together with the last equality above, yields

$$b - a > -\delta C\sqrt{1 - \tau^{2/r}(s_\delta)} \tan_\epsilon^{r-1}(s_\delta) + (n - r)\tau(s_\delta). \tag{28}$$

Letting $\delta \rightarrow 0$ on both sides of (28) gives $b - a \geq (n - r)b \geq b$, which is a contradiction. In the same way, we derive a contradiction if we assume $b < 0$. Therefore, except for the function τ_0 of Proposition 3, no graph of a solution to (26) has an endpoint at the y -axis, as we wished to prove. \square

Now, we are in position to state and prove our first main result.

Theorem 1 *Given integers $n \geq 2$ and $r \in \{1, \dots, n - 1\}$, the following hold:*

- (i) *There exists a rotational strictly convex r -translator Σ_0 in $\mathbb{Q}_\epsilon^n \times \mathbb{R}$ (to be called the r -bowl soliton) which is an entire vertical graph contained in the closed half-space $\mathbb{Q}_\epsilon^n \times [0, +\infty)$ with unbounded height (Fig. 5).*
- (ii) *If r is odd, there exists a one-parameter family $\mathcal{C}_r = \{\Sigma_\lambda; \lambda > 0\}$ of properly embedded annular rotational r -translators in $\mathbb{Q}_\epsilon^n \times \mathbb{R}$ (to be called r -translating catenoids) with the following properties (Fig. 6):*
 - *For each $\lambda > 0$, Σ_λ is the union of two graphs Σ_λ^- and Σ_λ^+ over the complement of the ball $B_\lambda(o) \subset \mathbb{Q}_\epsilon^n$ which have unbounded height and satisfy $\partial \Sigma_\lambda^\pm = \partial B_\lambda(o)$.*

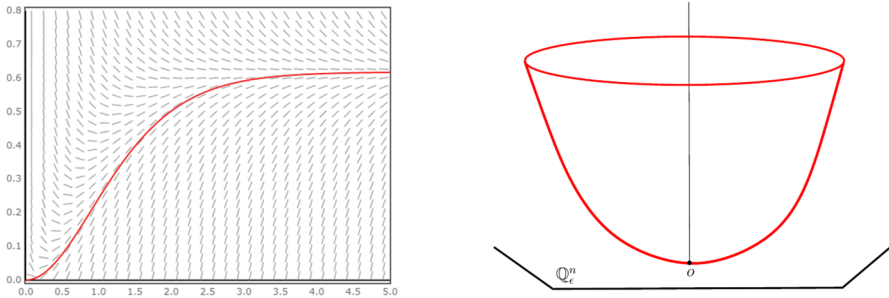

Fig. 5 The graph of τ_0 (left) and the r -bowl soliton obtained from it (right)

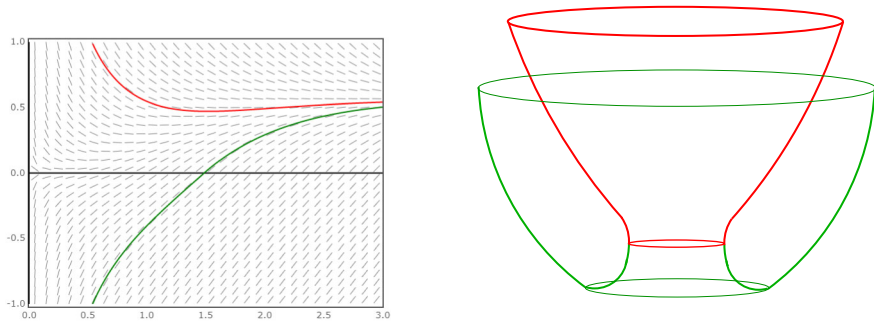

Fig. 6 The graphs of τ_λ^- and τ_λ^+ (left) and the r (odd)-translating catenoid Σ_λ obtained from them (right). For $r > 1$, Σ_λ is C^2 -singular on the horizontal $(n - 1)$ -sphere of minimal height

- Each r -translating catenoid $\Sigma_\lambda \in \mathcal{C}_r$ is contained in a half-space of $\mathbb{Q}_\epsilon^n \times \mathbb{R}$, and its set of points of minimal height is an $(n - 1)$ -sphere centered at the axis of rotation which is contained in a horizontal hyperplane $\Pi_t := \mathbb{Q}_\epsilon^n \times \{t\}$, $t < 0$.
- For $r > 1$, any r -translating catenoid $\Sigma_\lambda \in \mathcal{C}_r$ is C^2 -singular along its $(n - 1)$ -sphere of minimal height.
- For any $\lambda > 0$, the graphs Σ_λ^- and Σ_λ^+ have the same asymptotic behavior of the r -bowl soliton Σ_0 . More precisely, the angle functions Θ^-, Θ^+ , and Θ_0 , of $\Sigma_\lambda^-, \Sigma_\lambda^+$ and Σ_0 , respectively, satisfy:

$$\lim_{s \rightarrow +\infty} \Theta^-(s) = \lim_{s \rightarrow +\infty} \Theta^+(s) = \lim_{s \rightarrow +\infty} \Theta_0(s) = \Theta_L, \tag{29}$$

where Θ_L is the limit angle (cf. Definition 3).

- (iii) If r is even, there are two one-parameter families $\mathcal{C}_r^i = \{\Sigma_\lambda^i; \lambda > 0\}$, $i = 1, 2$, of properly embedded annular rotational r -translators in $\mathbb{Q}_\epsilon^n \times \mathbb{R}$ (to be called r -translating catenoids) with nonempty boundary. In addition, one has that (Fig. 7):

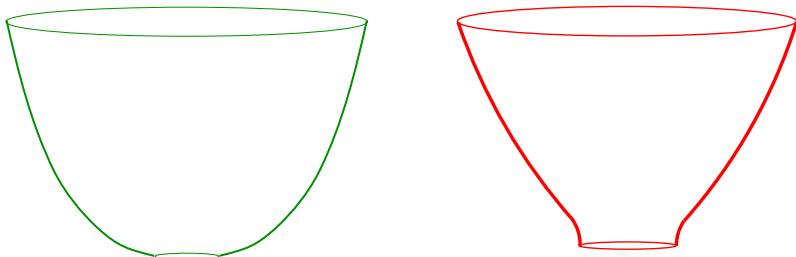

Fig. 7 r (even)-translating catenoids with boundary, where the one on the left belongs to \mathcal{C}_r^1 , whereas the one on the right belongs to \mathcal{C}_r^2

- For each $\lambda > 0$, Σ_λ^i is an unbounded graph in the half-space $\mathbb{Q}_\epsilon^n \times [0, +\infty)$ on the complement of a ball $B \subset \mathbb{Q}_\epsilon^n \times \{0\}$ centered at the rotation axis and of radius $R = R(\lambda) > 0$.
- Along their boundaries, the r -translators in \mathcal{C}_r^1 are tangent to the horizontal hyperplane Π_0 , whereas those in \mathcal{C}_r^2 are orthogonal to Π_0 .
- For any $\lambda > 0$, the angle functions Θ_λ^i and Θ_0 , of the graphs Σ_λ^i and the r -bowl soliton Σ_0 , respectively, satisfy:

$$\lim_{s \rightarrow +\infty} \Theta_\lambda^i(s) = \lim_{s \rightarrow +\infty} \Theta_0(s) = \Theta_L. \tag{30}$$

Proof Let ϱ_0 be as in Proposition 4. Then, by Proposition 1, the rotational entire graph Σ_0 with ϱ -function ϱ_0 and height function

$$\phi_0(s) = \int_0^s \frac{\varrho_0(u)}{\sqrt{1 - \varrho_0^2(u)}} du, \quad s \in [0, +\infty),$$

is an r -translator in $\mathbb{Q}_\epsilon^n \times \mathbb{R}$ (Fig. 5). Setting $\{o\} \times \mathbb{R}$, $o \in \mathbb{Q}_\epsilon^n$, for the axis of rotation of Σ_0 , we have from (6) (for $k_i^s = -\cot_\epsilon(s)$) and Proposition 4 that the principal curvatures of Σ_0 at o are well defined, so that Σ_0 is C^2 at o . Since $0 = \phi_0(0) < \phi_0(s)$ for all $s > 0$, we also have that Σ_0 is contained in the half-space $\mathbb{Q}_\epsilon^n \times [0, +\infty)$, and is tangent to $\mathbb{Q}_\epsilon^n \times \{0\}$ at o . In particular, Σ_0 is strictly convex at o . In addition, its height function ϕ_0 is unbounded. Indeed, since τ_0 , and so ϱ_0 , is increasing in $(0, +\infty)$, for any $a > 0$, one has

$$\phi_0(s) > \int_a^s \frac{\varrho_0(u)}{(1 - (\varrho_0(u))^2)^{1/2}} du \geq \int_a^s \varrho_0(u) du \geq \varrho_0(a)(s - a),$$

which clearly implies that ϕ_0 is unbounded. Finally, it follows from (6) (for $k_i^s = -\cot_\epsilon(s)$) and Proposition 3 that all principal curvatures $k_i(s)$ of Σ_0 are positive for $s > 0$, which gives that Σ_0 is strictly convex. This proves (i).

To prove (ii), set $s_0 = \lambda > 0$ and let τ_λ^- and τ_λ^+ be as in Proposition 2. Denote by Σ_λ^- and Σ_λ^+ the rotational graphs whose ϱ -functions are $\varrho_\lambda^- = (\tau_\lambda^-)^{1/r}$ and $\varrho_\lambda^+ = (\tau_\lambda^+)^{1/r}$,

and whose height functions are

$$\phi_\lambda^-(s) = \int_\lambda^s \frac{\varrho_\lambda^-(u)}{(1 - (\varrho_\lambda^-(u))^2)^{1/2}} du \quad \text{and} \quad \phi_\lambda^+(s) = \int_\lambda^s \frac{\varrho_\lambda^+(u)}{(1 - (\varrho_\lambda^+(u))^2)^{1/2}} du,$$

respectively.

Assume r odd. By Proposition 2-(i), there exists a unique $s(\lambda) > 0$ at which ϱ_λ^- vanishes, so that ϱ_λ^- is negative in the interval $(\lambda, s(\lambda))$, and positive in $(s(\lambda), +\infty)$. Then, $\phi_\lambda^-(s)$ is decreasing in $(\lambda, s(\lambda))$, and increasing in $(s(\lambda), +\infty)$. Furthermore, the tangent spaces of the closure of Σ_λ^- in $\mathbb{Q}_\epsilon^n \times \mathbb{R}$ along its boundary are all well defined and vertical, for $\varrho_\lambda^-(\lambda) = -1$.

Since $\tau_\lambda^-(s(\lambda)) = 0 < (\tau_\lambda^-)'(s(\lambda))$ and

$$(\varrho_\lambda^-)'(s) = \frac{1}{r} (\tau_\lambda^-(s))^{\frac{1-r}{r}} (\tau_\lambda^-)'(s),$$

if $r > 1$, one has $(\varrho_\lambda^-)'(s) \rightarrow +\infty$ as $s \rightarrow s(\lambda)$. From this and (6), we conclude that, for $r > 1$, the second fundamental form of Σ_λ^- blows up at all points of its $(n - 1)$ -sphere of (minimal) height $\phi(s(\lambda))$, i.e., Σ_λ^- is C^2 -singular at these points.

Since τ_λ^+ , and so ϱ_λ^+ , is positive in $[\lambda, +\infty)$, the same is true for ϕ_λ^+ . Besides, analogously to Σ_λ^- , the tangent spaces of the closure of Σ_λ^+ in $\mathbb{Q}_\epsilon^n \times \mathbb{R}$ along its boundary are all well defined and vertical. However, the boundaries of Σ_λ^- and Σ_λ^+ coincide with $\partial B_\lambda(o)$, and so we have that

$$\Sigma_\lambda := \text{closure}(\Sigma_\lambda^-) \cup \text{closure}(\Sigma_\lambda^+)$$

is an r -translator (Fig. 6). Furthermore, the argument we gave to prove that ϕ_0 is unbounded apply to ϕ_λ^- and ϕ_λ^+ , so that these functions are both unbounded as well. We also point out that Σ_λ is C^2 -smooth on the common boundary $\partial \Sigma_\lambda^\pm$ of Σ_λ^\pm . To see this, first observe that the principal curvatures on $\partial \Sigma_\lambda^-$ and $\partial \Sigma_\lambda^+$ are well defined. Indeed, recall that $\varrho_\lambda^-(\lambda) = -\varrho_\lambda^+(\lambda) = -1$ and that r is odd. So, on $\partial \Sigma_\lambda^-$, the principal curvatures k_i, \dots, k_n are given by

$$k_i = \alpha(\lambda)\varrho_\lambda^-(\lambda) = -\alpha(\lambda) = -\cot_\epsilon(\lambda) < 0, \quad i = 1, \dots, n - 1,$$

and

$$k_n = (\varrho_\lambda^-)'(\lambda) = \frac{1}{r} (\tau_\lambda^-(\lambda))^{\frac{1-r}{r}} (\tau_\lambda^-)'(\lambda) = \frac{1}{r} (\tau_\lambda^-)'(\lambda) > 0,$$

whereas on $\partial \Sigma_\lambda^+$

$$k_i = \alpha(\lambda)\varrho_\lambda^+(\lambda) = \alpha(\lambda) = \cot_\epsilon(\lambda) > 0,$$

and

$$k_n = (\varrho_\lambda^+)'(\lambda) = \frac{1}{r} (\tau_\lambda^+(\lambda))^{\frac{1-r}{r}} (\tau_\lambda^+)'(\lambda) = \frac{1}{r} (\tau_\lambda^+)'(\lambda) < 0.$$

Moreover, since τ_λ^+ and τ_λ^- are the solutions to (26) satisfying $y(\lambda) = 1$ and $y(\lambda) = -1$, respectively, we have that $(\tau_\lambda^+)'(\lambda) = -(\tau_\lambda^-)'(\lambda)$. Hence, after a change of orientation of either Σ_λ^- or Σ_λ^+ (see Remark 2), we conclude from the above equalities that Σ_λ is C^2 -smooth on $\partial\Sigma_\lambda^\pm$.

Now, by Proposition 3-(iv), the inequalities $\varrho_\lambda^-(s) < \varrho_0(s) < \varrho_\lambda^+(s)$ hold for all $s \in [\lambda, +\infty)$. Thus,

$$\phi_\lambda^-(s) < \phi_0(s) < \phi_\lambda^+(s) \quad \forall s \in [\lambda, +\infty).$$

In particular, Σ_λ is properly embedded.

To conclude the proof of (ii), we observe that equality (29) follows directly from the relation $\Theta^2 = 1 - \varrho^2$, equality (20), and Proposition 3-(iii).

To prove (iii), assume that r is even. In this case, keeping the notation above, we have to disregard the negative part of τ_λ^- , since $(\varrho_\lambda^-)^r \geq 0$. Then, we have

$$\varrho_\lambda^- = (\hat{\tau}_\lambda^-)^{1/r} \quad \text{and} \quad \varrho_\lambda^+ = (\tau_\lambda^+)^{1/r}, \tag{31}$$

where $\hat{\tau}_\lambda^- := \tau_\lambda^-|_{[s(\lambda), +\infty)} \geq 0$ and $s(\lambda) > 0$ satisfies $\tau_\lambda^-(s(\lambda)) = 0$.

Now, denote by Σ_λ^1 and Σ_λ^2 the rotational graphs whose ϱ -functions are ϱ_λ^- and ϱ_λ^+ , and whose height functions are

$$\phi_\lambda^1(s) = \int_{s(\lambda)}^s \frac{\varrho_\lambda^-(u)}{(1 - (\varrho_\lambda^-(u))^2)^{1/2}} du \quad \text{and} \quad \phi_\lambda^2(s) = \int_\lambda^s \frac{\varrho_\lambda^+(u)}{(1 - (\varrho_\lambda^+(u))^2)^{1/2}} du, \tag{32}$$

respectively. Then, proceeding as before, we conclude that each element of the family $\mathcal{C}_r^i := \{\Sigma_\lambda^i, \lambda > 0\}$, $i = 1, 2$, is an unbounded graph in $\mathbb{Q}_\epsilon^n \times [0, +\infty)$ as asserted. Also, since $\varrho_\lambda^-(s(\lambda)) = 0$ and $\varrho_\lambda^+(\lambda) = 1$, we have that the graphs Σ_λ^1 are tangent to $\mathbb{Q}_\epsilon^n \times \{0\}$ along their boundaries, whereas the graphs Σ_λ^2 are orthogonal to $\mathbb{Q}_\epsilon^n \times \{0\}$ (Fig. 7).

Finally, as it was for (29), equality (30) follows from the relation $\Theta^2 = 1 - \varrho^2$, equality (20), and Proposition 3-(iv). This shows (iii) and finishes our proof. \square

Remark 4 Regarding Theorem 1-(ii), the $r(> 1)$ -th mean curvature H_r of any translating catenoid $\Sigma_\lambda \in \mathcal{C}_r$ extends C^1 -smoothly to the C^2 -singular $(n - 1)$ -sphere of minimal height, and equals 1 there. Hence, despite the fact that $r(> 1)$ -translating catenoids have C^2 -singular sets when r is odd, they move under H_r -flow, that is, they are genuine r -translators. The same goes for the other translators with C^2 -singular sets we shall obtain in the next sections.

Remark 5 In the above setting, it is not hard to prove that, for any $s_0 > 0$, the solution τ_{s_0} to (26) has a local minimum $s_* = s_*(s_0)$, and that $(s_*(s_0), \tau(s_*(s_0)))$ converges to $(0, 0)$ as $s_0 \rightarrow 0$ (see Fig. 8). As a consequence, the restriction of $\tau_{s_0}^+$ to $(s_*(s_0), +\infty)$ converges uniformly to the solution τ_0 as $s_0 \rightarrow 0$. By the definition of τ_0 , the same is true for the restriction of $\tau_{s_0}^-$ to the interval where it is positive. Thus, writing $\lambda = s_0$, the subsets of the translating catenoids Σ_λ generated by these restrictions of $\tau_{s_0}^\pm$ converge (in compact sets) to the bowl soliton Σ_0 as $\lambda \rightarrow 0$.

Fig. 8 Graphs of solutions $\tau_{s_0}^+$ to (26). As $s_0 \rightarrow 0$, the points of minimal height converge to $(0, 0)$

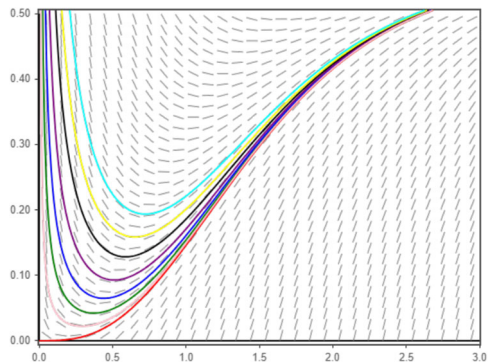

Remark 6 For r even, $-\varrho$ is a solution to (16) whenever ϱ is a solution. Hence, in (31), we could have chosen the negative functions $\varrho_\lambda^- = -(\hat{\tau}_\lambda^-)^{1/r}$ and $\varrho_\lambda^+ = -(\hat{\tau}_\lambda^+)^{1/r}$. However, the corresponding graphs $\bar{\Sigma}_\lambda^i$ obtained from the functions ϕ_λ^i as in (32) would be congruent to the ones in \mathcal{C}_r^i . Indeed, as one can easily check, $\bar{\Sigma}_\lambda^i$ is nothing but the reflection of Σ_λ^i about the horizontal hyperplane $\mathbb{Q}_\epsilon^n \times \{0\}$. (Recall that, as we pointed out in Remark 3, $\bar{\Sigma}_\lambda^i$ is an r -translator when it is properly oriented.) These considerations apply to the r (even)-translators with boundary we shall obtain in the next sections.

We close this section with the following uniqueness result.

Proposition 6 *Let Σ be a connected rotational $r(<n)$ -translator in $\mathbb{Q}_\epsilon^n \times \mathbb{R}$ which is a vertical graph over an open set of \mathbb{Q}_ϵ^n . Then, Σ is an open set of either an r -bowl soliton or an r -translating catenoid.*

Proof Since Σ is rotational, it constitutes an (M_s, ϕ) -graph such that the parallels M_s are geodesic spheres of \mathbb{Q}_ϵ^n . Hence, by Proposition 1, the ϱ -function of Σ satisfies (16) for $\alpha = \cot_\epsilon$, which implies that $\tau := \varrho^r$ is a solution to (26) defined in an interval $I \subset [0, +\infty)$. Thus, from Proposition 5, τ is the restriction to I of either the function τ_0 defined in Proposition 3, or one of the solutions $\tau_{s_0}^\pm$ defined in Proposition 2. It follows then by (the proof of) Theorem 1 that Σ is an open set of either the r -bowl soliton or an r -translating catenoid. \square

5 Parabolic Translators to $r(<n)$ -MCF in $\mathbb{H}^n \times \mathbb{R}$

We shall consider now parabolic $r(<n)$ -translators in $\mathbb{H}^n \times \mathbb{R}$, that is, those which are invariant by horizontal parabolic translations. More precisely, such a translator will be obtained from (\mathcal{H}_s, ϕ) -graphs, where

$$\mathcal{H} := \{\mathcal{H}_s; s \in I \subset (-\infty, +\infty)\}$$

is a family of horospheres of \mathbb{H}^n centered at a fixed point p_∞ of the ideal boundary $\partial_\infty \mathbb{H}^n$ of \mathbb{H}^n .

Fig. 9 Graphs of solutions to the Cauchy problem (34)

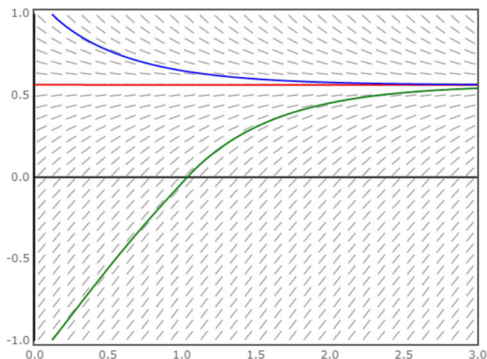

For the family \mathcal{H} , we have that α is the constant function 1 (notation as in Sect. 3). So, Eq. (17) becomes

$$\tau'(s) = C\sqrt{1 - \tau^{2/r}(s)} - (n - r)\tau(s), \tag{33}$$

and the associated Cauchy problem is:

$$\begin{cases} y'(s) = F(y(s)) \\ y(s_0) = y_0, \end{cases} \tag{34}$$

where $(s_0, y_0) \in \Omega := (-\infty, +\infty) \times [-1, 1]$, and $F = F_{(n,r)}$ is the function:

$$F(y) := C\sqrt{1 - y^{2/r}} - (n - r)y, \quad 1 \leq r < n, \quad y \in [-1, 1]. \tag{35}$$

Figure 9 shows the graphs of some solutions to (34). As we pointed out in the proof of Proposition 2, the constant function $\tau_L = L$ is a solution, where L is the limit constant (red curve). The blue and green curves are the graphs of solutions of the type $\tau_{s_0}^\pm$, described in Proposition 2.

Theorem 2 *Given integers $n \geq 2$ and $r \in \{1, \dots, n - 1\}$, the following hold:*

- (i) *There exists a parabolic convex r -translator Σ_L in $\mathbb{H}^n \times \mathbb{R}$ (to be called the parabolic r -bowl soliton) which is an entire vertical graph with unbounded height function, from above and from below (Fig. 10). In addition, one has:*
 - *the angle function Θ of Σ_L is constant and satisfies $\Theta = \Theta_L$.*
 - *all principal curvatures of Σ_L are constant.*
 - *Σ_L is isoparametric.*
- (ii) *If r is odd, there is a properly embedded parabolic r -translator Σ in $\mathbb{H}^n \times \mathbb{R}$ (to be called the parabolic r -translating catenoid) which is homeomorphic to Euclidean space \mathbb{R}^n . In addition, the following assertions hold (Fig. 11):*
 - *Σ is the union of two graphs Σ^- and Σ^+ over the complement of the horoball bounded by the horosphere $\mathcal{H}_0 \subset \mathbb{H}^n$, both unbounded from above, such that $\partial \Sigma^\pm = \mathcal{H}_0$.*

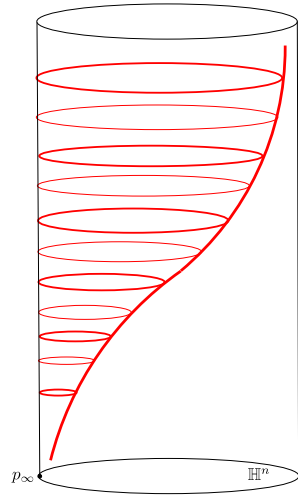
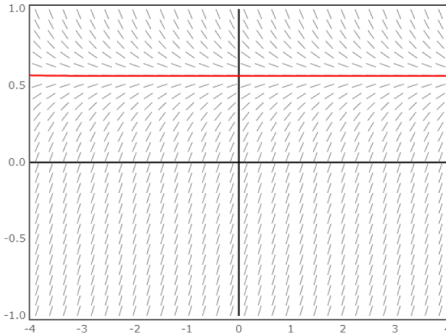

Fig. 10 The graph of the constant function $\tau_L \equiv L$ (left) and the parabolic r -bowl soliton obtained from it (right)

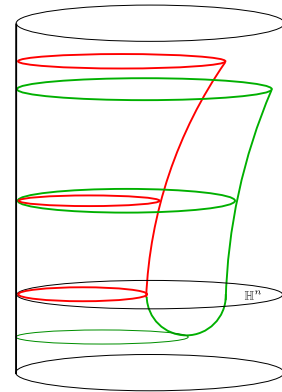
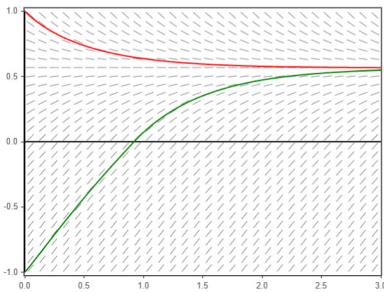

Fig. 11 The graphs of τ_0^- and τ_0^+ (left) and the parabolic r (odd)-translating catenoid Σ_λ obtained from them (right). For $r > 1$, Σ_λ is C^2 -singular on the horizontal horosphere of minimal height

- Σ is contained in a half-space of $\mathbb{H}^n \times \mathbb{R}$, and its set of points of minimal height is a horosphere in a horizontal hyperplane Π_t , $t < 0$.
- For $r > 1$, Σ is C^2 -singular along its horosphere of minimal height.
- The graphs Σ^- and Σ^+ are asymptotic to the constant angle parabolic r -bowl soliton Σ_L . More precisely, the angle functions Θ^- and Θ^+ of Σ^- and Σ^+ , respectively, satisfy:

$$\lim_{s \rightarrow +\infty} \Theta^-(s) = \lim_{s \rightarrow +\infty} \Theta^+(s) = \Theta_L.$$

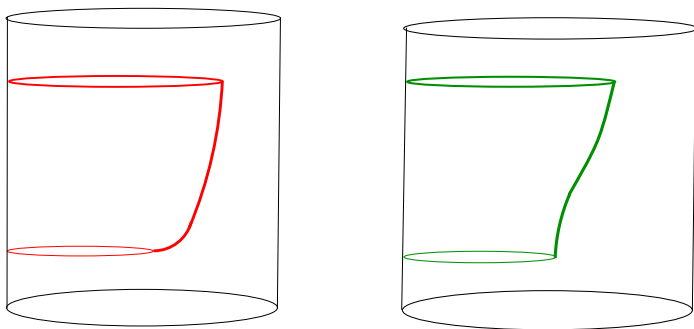

Fig. 12 Parabolic r (even)-translating catenoids Σ_1 (left) and Σ_2 (right)

(iii) If r is even, there are two properly embedded parabolic r -translators Σ_1 and Σ_2 in $\mathbb{H}^n \times \mathbb{R}$ (to be called parabolic r -translating catenoids), both with nonempty boundary and homeomorphic to the half-space $\mathbb{R}^{n-1} \times [0, +\infty)$. In addition, one has that (Fig. 12):

- Σ_1 and Σ_2 are both unbounded graphs in the half-space $\mathbb{H}^n \times [0, +\infty)$ on the complement of a horoball in Π_0 .
- Along its boundary, the r -translator Σ_1 is tangent to Π_0 , whereas Σ_2 is orthogonal to Π_0 .
- Denoting by Θ the angle function of either Σ_1 or Σ_2 , one has:

$$\lim_{s \rightarrow +\infty} \Theta(s) = \Theta_L.$$

Proof Let $\tau_L = L$ be the constant solution to (34) and set $\varrho_L = \tau_L^{1/r}$. Then, by Proposition 1, the (\mathcal{H}_s, ϕ) -graph Σ_L with ϱ -function ϱ_L and height function

$$\phi_L(s) = \int_0^s \frac{\varrho_L}{\sqrt{1 - \varrho_L^2}} du = \frac{\varrho_L}{\sqrt{1 - \varrho_L^2}} s, \quad s \in (-\infty, +\infty), \tag{36}$$

is an r -translator in $\mathbb{H}^n \times \mathbb{R}$.

Since ϕ_L is a linear function on \mathbb{R} , Σ_L is an entire graph over Π_0 whose height function is unbounded from above and from below (Fig. 10). Moreover, the angle function of Σ_L is constant and coincides with the limit angle Θ_L , for

$$\Theta_L^2 = 1 - L^{2/r} = 1 - \varrho_L^2.$$

In addition, it follows from (6) (for $\alpha = 1$) that the principal curvatures k_i of Σ_L are all constant and positive, except for k_n , which vanishes everywhere. In particular, Σ_L is convex and it has constant mean curvature, regardless the value of r .

Finally, to prove that Σ_L is isoparametric (see Sect. 2.1), for each $u \in \mathbb{R}$, denote by Σ_L^u the parallel hypersurface of $\mathbb{H}^n \times \mathbb{R}$ at distance u from Σ_L . Recall from (3) that

$\Sigma_L = f(\mathcal{H}_0 \times \mathbb{R})$, where f is the immersion

$$f(p, s) = (\gamma_p(s), \phi_L(s)), \quad (p, s) \in \mathcal{H}_0 \times \mathbb{R},$$

being γ_p the geodesic of \mathbb{H}^n given by $\gamma_p(s) := \exp_p(s\eta_0(p))$. Also, from (4), the unit normal N of Σ_L at $f(p, s)$ is

$$N = -\varrho_L \eta_s(p) + \Theta_L \partial_t. \tag{37}$$

Given $s \in \mathbb{R}$, write $\tilde{s} = s - u\varrho_L$. Then, from the linearity of ϕ_L , we have that $\phi_L(s) = \phi_L(\tilde{s}) + u\phi_L(\varrho_L)$. From this, (8), and (36), one easily gets

$$\phi_L(s) + u\Theta_L = \phi_L(\tilde{s}) + \frac{u}{\sqrt{1 - \varrho_L^2}}. \tag{38}$$

Now, denoting by $\overline{\text{exp}}$ the exponential map of $\mathbb{H}^n \times \mathbb{R}$, one has that $\Sigma_L^u = f^u(\mathcal{H}_0 \times \mathbb{R})$, where f^u is the immersion

$$f^u(p, s) = \overline{\text{exp}}_{f(p,s)}(uN(f(p, s))), \quad (p, s) \in \mathcal{H}_0 \times \mathbb{R}. \tag{39}$$

Then, observing that $\eta_s = \gamma'_p(s)$, we have from (37), (38) and (39) that

$$\begin{aligned} f^u(p, s) &= (\exp_{\gamma_p(s)}(-u\varrho_L\gamma'_p(s)), \phi_L(s) + u\Theta_L) \\ &= (\exp_p((s - u\varrho_L)\eta_0(p)), \phi_L(s) + u\Theta_L) \\ &= \left(\exp_p(\tilde{s}\eta_0(p)), \phi_L(\tilde{s}) + \frac{u}{\sqrt{1 - \varrho_L^2}} \right), \end{aligned}$$

which shows that Σ_L^u is nothing but a vertical translation of Σ_L . Therefore, for any $u \in \mathbb{R}$, Σ_L^u has constant principal curvatures and, in particular, constant mean curvature, giving that Σ_L is indeed isoparametric. This proves (i).

Considering the fact that Proposition 2 holds for $\alpha = 1$, we conclude that the proofs of (ii) and (iii) are completely analogous to the ones given for assertions (ii) and (iii) of Theorem 1. □

Remark 7 For $n = 2$ and $r = 1$, the parabolic r -bowl-soliton was previously obtained in [9] as an element of a one-parameter family of isoparametric surfaces of $\mathbb{H}^2 \times \mathbb{R}$ called *parabolic helicoids*.

Remark 8 With the notation of Proposition 2, we have from (33) that

$$\tau_{s_0}(s) = \tau_0(s - s_0) \quad \forall s \in (s_0, +\infty), s_0 \in \mathbb{R}.$$

From this equality, we conclude that the height functions of the (\mathcal{H}_s, ϕ) -graphs associated to two distinct solutions of (33) differ by a vertical translation in $\mathbb{H}^n \times \mathbb{R}$, so

that they are congruent. Notice that this contrasts with the rotational case considered in the preceding section (cf. Theorem 1, items (ii) and (iii)).

Regarding the Cauchy problem (34), since $\partial\Omega = \mathbb{R} \times \{-1\} \cup \mathbb{R} \times \{1\}$, we have that the only solutions are the constant function τ_L , and those of the type $\tau_{s_0}^\pm$. From this fact, and the considerations of Remark 8, we conclude that a version of the uniqueness result for rotational $r(<n)$ -translators obtained in Proposition 6 holds for parabolic $r(<n)$ -translators as well. The proof is completely analogous. More precisely, we have

Proposition 7 *Let Σ be a connected parabolic $r(<n)$ -translator in $\mathbb{H}^n \times \mathbb{R}$ which is a vertical graph over an open set of \mathbb{H}^n . Then, up to an ambient isometry, Σ is an open set of either the parabolic r -bowl soliton or a parabolic r -translating catenoid.*

6 Hyperbolic Translators to $r(<n)$ -MCF in $\mathbb{H}^n \times \mathbb{R}$

In analogy with the preceding section, we consider now hyperbolic $r(<n)$ -translators in $\mathbb{H}^n \times \mathbb{R}$, i.e., those which are invariant by horizontal hyperbolic translations of $\mathbb{H}^n \times \mathbb{R}$. So, they will be constructed from (\mathcal{E}_s, ϕ) -graphs, where

$$\mathcal{E} := \{\mathcal{E}_s; s \in I \subset (-\infty, +\infty)\}$$

is a family of hypersurfaces of \mathbb{H}^n which are equidistant from a fixed totally geodesic hyperplane $\mathcal{E}_0 \subset \mathbb{H}^n$. The open interval I defining the family \mathcal{E} is:

$$I := \begin{cases} (-\infty, +\infty) & \text{if } r = 1, \\ (0, +\infty) & \text{if } r > 1. \end{cases}$$

In this setting, with the notation of Sect. 3, we have that $\alpha = \tanh$. Hence, equation (17) becomes

$$\tau'(s) = C\sqrt{1 - \tau^{2/r}(s)} \coth^{r-1}(s) - (n - r) \tanh(s)\tau(s), \tag{40}$$

and the associated Cauchy problem is:

$$\begin{cases} y'(s) = F(s, y(s)) \\ y(s_0) = y_0, \end{cases} \tag{41}$$

where $(s_0, y_0) \in \Omega := I \times [-1, 1]$ and $F = F_{(n,r)}$ is the function:

$$F(s, y) := C\sqrt{1 - y^{2/r} \coth^{r-1}(s)} - (n - r) \tanh(s)y, \quad 1 \leq r < n, \quad (s, y) \in \Omega. \tag{42}$$

Figure 13 shows the graphs of some solutions to the Cauchy problem (41) for the cases $r = 1$ and $r > 1$.

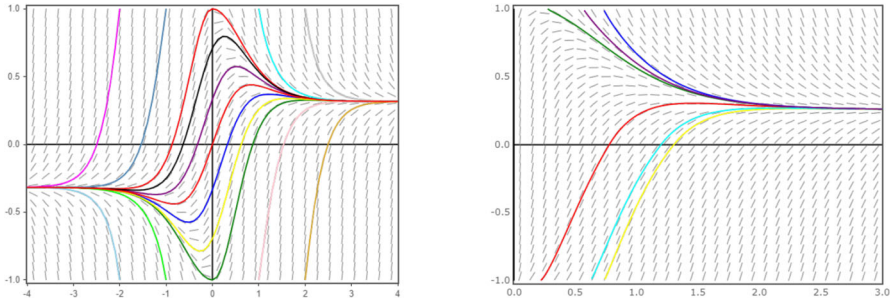

Fig. 13 Graphs of solutions to (41) for $F_{(4,1)}$ (left), and $F_{(4,3)}$ (right)

Proposition 8 For $r = 1$ and $\lambda \in [-1, 1]$, the solution τ_λ to (41) satisfying $\tau_\lambda(0) = \lambda$ is defined in $(-\infty, +\infty)$ and satisfies (cf. Fig. 13, left):

$$\lim_{s \rightarrow \pm\infty} \tau_\lambda(s) = \pm L.$$

Proof For $r = 1$, the function $F = F_{(n,r)}$ is

$$F(s, y) = \sqrt{1 - y^2} - (n - 1) \tanh(s)y, \tag{43}$$

which is bounded on any strip $\Omega_\delta = I_\delta \times [-1, 1] \subset \Omega$, where $I_\delta := (-\delta, \delta) \ni 0$. So, for a sufficiently small δ , τ_λ is well defined in I_δ for all $\lambda \in (-1, 1)$.

For $\lambda = \pm 1$, we have that $\tau'_\lambda(0) = 0$. In addition, F is bounded in Ω_δ . Hence, as $\lambda \rightarrow \pm 1$, the solutions τ_λ , $\lambda \neq \pm 1$, converge uniformly to the solutions $\tau_{\pm 1}$. As a consequence, possibly taking a smaller δ , $\tau_{\pm 1}$ are both defined in I_δ .

Since $F(s_0, 1) < 0 < F(s_0, -1)$ (resp. $F(s_0, -1) < 0 < F(s_0, 1)$) for $s_0 > 0$ (resp. $s_0 < 0$), for any $\lambda \in [-1, 1]$, we have that $\tau_\lambda(s) \neq \pm 1$ for all $s \in I_{\max}$, which implies that $I_{\max} = (-\infty, +\infty)$.

Now, arguing as in the proof of Proposition 2, one easily concludes that each function τ_λ has at most two critical points, so that

$$L^\lambda_\pm := \lim_{s \rightarrow \pm\infty} \tau_\lambda(s)$$

is well defined and $\lim_{s \rightarrow \pm\infty} \tau'_\lambda(s) = 0$.

These last two equalities and (40) then yield

$$\sqrt{1 - (L^\lambda_\pm)^2} \mp (n - 1)L^\lambda_\pm = 0,$$

which implies that $-L^\lambda_- = L^\lambda_+ = L$. □

Proposition 9 The only solutions to the Cauchy problem (41) which are defined in a maximal interval are the functions $\tau_{s_0}^\pm$ of Proposition 2, and the functions τ_λ of Proposition 8 (if $r = 1$).

Proof The result is immediate for $r = 1$, for in this case we have

$$\partial\Omega = \mathbb{R} \times \{-1\} \cup \mathbb{R} \times \{1\},$$

so that the endpoint of a solution to (41), if it exists, has y -coordinate -1 or 1 .

Now, let us suppose that $1 < r < n$. In this case, it suffices to prove that there is no solution to (26) whose graph has an endpoint of the form $p := (0, a)$. Arguing as in the proof of Proposition 5, assume, by contradiction, that such a solution exists and call it τ . We can also assume, without loss of generality, that $a > 0$. Extending τ to 0 by making $\tau(0) = a$, it is easily seen that the graph \mathcal{G} of τ is tangent to the y -axis at p .

Choose a small $c > 0$ such that $\tau' > 0$ on $(0, c)$, and set $b := \tau(c) > 0$. Given a positive $\delta < c$, set \mathcal{S}_δ for the line segment from $p = (0, a)$ to (δ, b) and write $p_\delta = \mathcal{S}_\delta \cap \mathcal{G}$. By Rolle’s Theorem, there exists a point $q_\delta := (s_\delta, \tau(s_\delta))$ in the open arc of \mathcal{G} from p to p_δ such that the tangent line to \mathcal{G} at q_δ is parallel to \mathcal{S}_δ , which yields $\tau'(s_\delta) = (b - a)/\delta$. Thus, by (40),

$$C\sqrt{1 - \tau^{2/r}(s_\delta)} \coth^{r-1}(s_\delta) - (n - r) \tanh(s_\delta)\tau(s_\delta) = \frac{b - a}{\delta}.$$

Since $0 < s_\delta < \delta$, we have that $\delta \coth^{r-1}(s_\delta) > s_\delta \coth^{r-1}(s_\delta) \geq 1$. This, together with the last equality above, yields

$$b - a > C\sqrt{1 - \tau^{2/r}(s_\delta)} - (n - r)\delta \tanh(s_\delta)\tau(s_\delta). \tag{44}$$

Letting $\delta \rightarrow 0$ on both sides of (44) gives $b - a \geq C\sqrt{1 - a^{2/r}}$, which is a contradiction, since we can choose $c > 0$ in such a way that $b = \tau(c)$ is arbitrarily close to a . This finishes the proof. \square

Theorem 3 *Given integers $n \geq 2$ and $r \in \{1, \dots, n - 1\}$, the following hold:*

- (i) *For $r = 1$, there exists a one-parameter family $\mathcal{B} = \{\Sigma_\lambda; \lambda \in [-1, 0]\}$ of hyperbolic r -translators (to be called hyperbolic bowl solitons) with the following properties:*
 - *For each $\lambda \in (-1, 0)$, Σ_λ is an entire vertical graph contained in the half-space $\mathbb{H}^n \times [0, +\infty)$ with unbounded height function, which is tangent to an equidistant hypersurface $\mathcal{E}_{s(\lambda)} \in \mathcal{E}$ (Fig. 14).*
 - *For $\lambda = -1$, Σ_λ is a complete graph over a half-space of \mathbb{H}^n determined by the hyperplane \mathcal{E}_0 , which is asymptotic to $\mathcal{E}_0 \times [0, +\infty)$. In addition, Σ_λ is contained in the half-space $\mathbb{H}^n \times [0, +\infty)$ with unbounded height function, being tangent to an equidistant hypersurface $\mathcal{E}_{s(\lambda)} \in \mathcal{E}$ (Fig. 15).*
- (ii) *For $r = 1$, there exists a one-parameter family $\mathcal{G} = \{\Sigma_\mu; \mu \in (-\infty, 0)\}$ of hyperbolic r -translators (to be called hyperbolic 1-grim reapers). Each translator $\Sigma_\mu \in \mathcal{G}$ is a complete graph over a half-space of \mathbb{H}^n determined by the hyperplane \mathcal{E}_0 , which is asymptotic to $\mathcal{E}_0 \times [0, -\infty)$, intersects $\mathbb{H}^n \times \{0\}$ along \mathcal{E}_μ , and has unbounded (above and below) height function (Fig. 16).*

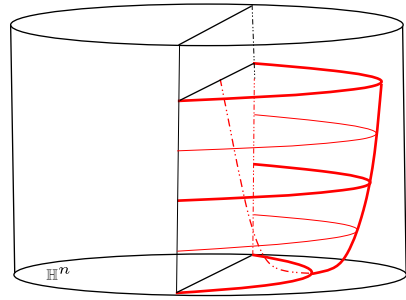
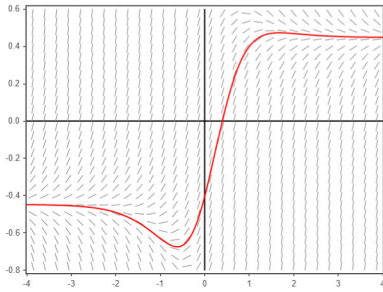

Fig. 14 The graph of τ_λ (left) and part of the hyperbolic bowl soliton Σ_λ obtained from it (right)

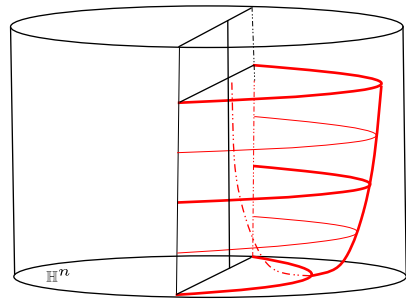
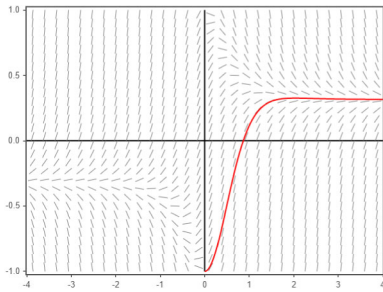

Fig. 15 The graph of τ_{-1} on $(0, +\infty)$ (left) and the hyperbolic bowl soliton Σ_{-1} obtained from it (right)

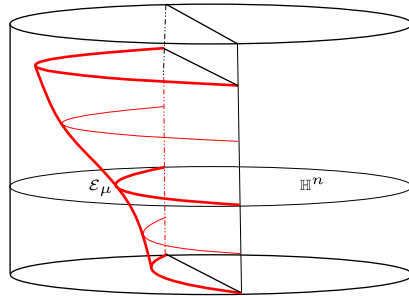
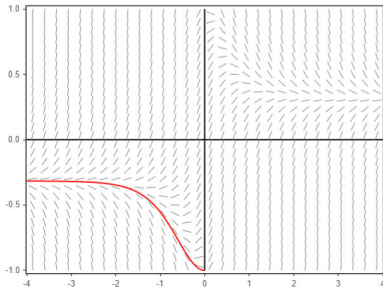

Fig. 16 The graph of τ_{-1} on $(-\infty, 0)$ (left) and the hyperbolic grim reaper Σ_μ obtained from it (right)

(iii) If r is odd, there exists a one-parameter family $\mathcal{C}_r = \{\Sigma_\lambda; \lambda \in (0, +\infty)\}$ of properly embedded hyperbolic r -translators in $\mathbb{H}^n \times \mathbb{R}$ (to be called hyperbolic r -translating catenoids) which are all homeomorphic to Euclidean space \mathbb{R}^n . In addition, one has that (Fig. 17):

- For each $\lambda \in (0, +\infty)$, Σ_λ is the union of two graphs Σ_λ^- and Σ_λ^+ , both unbounded from above, over one of the connected components of the complement of the convex region of \mathbb{H}^n bounded by \mathcal{E}_0 and \mathcal{E}_λ .

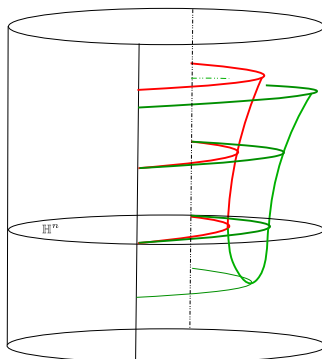
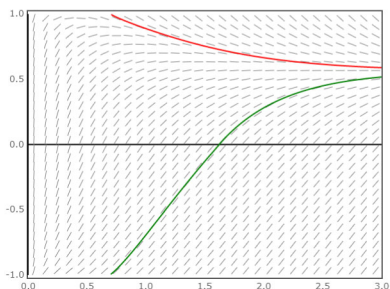

Fig. 17 The graphs of τ_λ^- and τ_λ^+ (left) and the hyperbolic r (odd)-translating catenoid Σ_λ obtained from them (right). For $r > 1$, Σ_λ is C^2 -singular on the horizontal equidistant hypersurface of minimal height

- Each hyperbolic r -translating catenoid $\Sigma_\lambda \in \mathcal{C}_r$ is contained in a half-space of $\mathbb{H}^n \times \mathbb{R}$, and its set of points of minimal height is an equidistant hypersurface in a horizontal hyperplane Π_t , $t < 0$.
- For $r > 1$, any hyperbolic r -translating catenoid $\Sigma_\lambda \in \mathcal{C}_r$ is C^2 -singular along its equidistant hypersurface of minimal height.
- For any $\lambda \in (0, +\infty)$, the angle functions Θ^- and Θ^+ of Σ_λ^- and Σ_λ^+ , respectively, satisfy:

$$\lim_{s \rightarrow +\infty} \Theta^-(s) = \lim_{s \rightarrow +\infty} \Theta^+(s) = \Theta_L,$$

where Θ_L is the limit angle.

(iv) If r is even, there are two one-parameter families $\mathcal{C}_r^i = \{\Sigma_\lambda^i; \lambda > 0\}$, $i = 1, 2$, of properly embedded hyperbolic r -translators in $\mathbb{H}^n \times \mathbb{R}$ (to be called hyperbolic r -translating catenoids) with nonempty boundary, which are all homeomorphic to a half-space $\mathbb{R}^n \times [0, +\infty)$. In addition, one has (Fig. 18):

- For each $\lambda > 0$, Σ_λ^i is an unbounded graph in $\mathbb{H}^n \times [0, +\infty)$ over one of the connected components of the complement of the convex region of \mathbb{H}^n bounded by \mathcal{E}_0 and an equidistant \mathcal{E}_λ , $\bar{\lambda} = \bar{\lambda}(\lambda)$.
- Along their boundaries, the r -translators in \mathcal{C}_r^1 are tangent to the horizontal hyperplane Π_0 , whereas those in \mathcal{C}_r^2 are orthogonal to Π_0 .
- For each $\lambda > 0$, the angle function Θ_λ^i of $\Sigma_\lambda^i \in \mathcal{C}_r^i$ satisfies:

$$\lim_{s \rightarrow +\infty} \Theta_\lambda^i(s) = \Theta_L.$$

Proof (i) Given $\lambda \in (-1, 0]$, let $\tau_\lambda : (-\infty, +\infty) \rightarrow \mathbb{R}$ be as in Proposition 8. Set Σ_λ for the $(\mathcal{E}_s, \phi_\lambda)$ -graph with ϱ -function $\varrho_\lambda = \tau_\lambda$ and height function

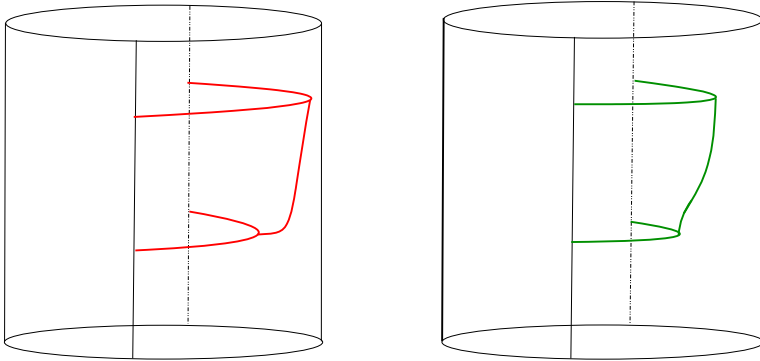

Fig. 18 Hyperbolic r (even)-translating catenoids with boundary, where the one on the left belongs to \mathcal{C}_r^1 , whereas the one on the right belongs to \mathcal{C}_r^2

$$\phi_\lambda(s) = \int_{s(\lambda)}^s \frac{\varrho_\lambda(u)}{\sqrt{1 - \varrho_\lambda^2(u)}} du, \quad s \in (-\infty, +\infty),$$

where $s(\lambda)$ satisfies $\varrho_\lambda(s(\lambda)) = 0$. Then, Σ is an entire graph over \mathbb{H}^n and, by Proposition 1, is a translator to MCF in $\mathbb{H}^n \times \mathbb{R}$. Also, since ϱ_λ is negative in $(-\infty, s(\lambda))$ and positive in $(s(\lambda), +\infty)$, we have that $\phi_\lambda(s) > 0$ for all $s \neq s(\lambda)$, which implies that Σ_λ is contained in the half-space $\mathbb{H}^n \times [0, +\infty)$, and is tangent to the equidistant hypersurface $\mathcal{E}_{s(\lambda)} \subset \mathbb{H}^n \times \{0\}$, for $\phi_\lambda(s(\lambda)) = \phi'_\lambda(s(\lambda)) = 0$ (Fig. 14).

To prove that ϕ_λ is unbounded, notice that the function $\varrho_\lambda/\sqrt{1 - \varrho_\lambda^2}$ is bounded below by a positive constant C_0 in any interval $(a, +\infty)$ with $a > s(\lambda)$ sufficiently large, for

$$\lim_{s \rightarrow +\infty} \frac{\varrho_\lambda(s)}{\sqrt{1 - \varrho_\lambda^2(s)}} = \frac{L}{\sqrt{1 - L^2}} > 0.$$

Then, for any $s \in (a, +\infty)$, one has

$$\phi_\lambda(s) > \int_a^s \frac{\varrho_0(u)}{\sqrt{1 - \varrho_0^2(u)^2}} du \geq C_0(s - a),$$

which implies that ϕ_λ is unbounded.

Now, assume that $\lambda = -1$ and consider the (\mathcal{E}_s, ϕ) -graph Σ defined by $\varrho = \tau_{-1}$ with $s > 0$. Then, the height function ϕ of Σ is

$$\phi(s) = \int_{s(-1)}^s \frac{\varrho(u)}{\sqrt{1 - \varrho^2(u)}} du, \quad s \in (0, +\infty).$$

As above, Σ has unbounded height function, is contained in $\mathbb{H}^n \times [0, +\infty)$, and is tangent to the equidistant hypersurface $\mathcal{E}_{s(-1)} \subset \mathbb{H}^n \times \{0\}$. So, it remains to prove that Σ is complete and asymptotic to $\mathcal{E}_0 \times [0, +\infty)$.

We have that $\varrho^2(0) = 1$, $(\varrho^2)'(0) = 0$, and $(\varrho^2)''(0) = -2\varrho''(0) \leq 0$, since $s = 0$ is a minimum of ϱ . So, the second order Taylor’s formula of ϱ^2 around $s = 0$ is

$$\varrho^2(s) = 1 + \frac{1}{2}(\varrho^2)''(0)s^2 + f(s), \quad \lim_{s \rightarrow 0} \frac{f(s)}{s^2} = 0. \tag{45}$$

Setting $a := (\varrho^2)''(s_{\max})/2$, we have from (45) that

$$\lim_{s \rightarrow 0} \frac{\sqrt{1 - \varrho^2(s)}}{|s|} = \sqrt{-a} > 0. \tag{46}$$

Now, by successive applications of the l’Hôpital’s rule, we have from (45) that

$$\lim_{s \rightarrow 0} \frac{f(s)}{s^3} = \lim_{s \rightarrow 0} \frac{(\varrho^2)'(s) - 2as}{3s^2} = \lim_{s \rightarrow 0} \frac{(\varrho^2)''(s) - 2a}{6s} = \frac{(\varrho^2)'''(0)}{6} \neq \pm\infty. \tag{47}$$

Finally, let us check that the function

$$g(s) := \frac{1}{\sqrt{1 - \varrho^2(s)}} - \frac{1}{\sqrt{-a}(-s)}$$

is well defined and bounded in a neighborhood of 0. With this purpose, we first observe that, from (45), we have

$$f(s) = (\sqrt{-a}(-s) - \sqrt{1 - \varrho^2(s)})(\sqrt{-a}(-s) + \sqrt{1 - \varrho^2(s)}).$$

Therefore, we can write g as

$$\begin{aligned} g(s) &= \frac{\sqrt{-a}(-s) - \sqrt{1 - \varrho^2(s)}}{\sqrt{-a}(1 - \varrho^2(s))(-s)} \\ &= \frac{1}{\sqrt{-a}\sqrt{1 - \varrho^2(s)}} \frac{1}{(-s)} \frac{f}{\sqrt{1 - \varrho^2(s)} + \sqrt{-a}(-s)} \\ &= \frac{-s}{\sqrt{-a}\sqrt{1 - \varrho^2(s)}} \frac{f}{(-s)^3} \frac{1}{\frac{\sqrt{1 - \varrho^2(s)}}{-s} + \sqrt{-a}}. \end{aligned}$$

This last equality, together with (46) and (47), gives that $\lim_{s \rightarrow 0} g(s)$ is well defined and finite, which proves our claim.

To conclude the proof of (i), fix a small $\delta > 0$ such that $\delta < s(-1)$. Then, for all $s \in (0, \delta)$, one has

$$\begin{aligned} \phi(s) &= \int_{s(-1)}^\delta \frac{\varrho(u)}{\sqrt{1-\varrho^2(u)}} du + \int_\delta^s \frac{\varrho(u)}{\sqrt{1-\varrho^2(u)}} du \\ &\geq \int_{s(-1)}^\delta \frac{\varrho(u)}{\sqrt{1-\varrho^2(u)}} du + \varrho(\delta) \int_\delta^s \frac{1}{\sqrt{1-\varrho^2(u)}} du. \end{aligned} \tag{48}$$

However, by the definition of g , we have

$$\begin{aligned} \int_\delta^s \frac{1}{\sqrt{1-\varrho^2(u)}} du &= \int_\delta^s g(u) du + \frac{1}{\sqrt{-a}} \int_\delta^s \frac{du}{-u} \\ &= \int_\delta^s g(u) du + \frac{1}{\sqrt{-a}} \log\left(\frac{\delta}{s}\right). \end{aligned} \tag{49}$$

Since g is continuous and bounded in $[0, \delta]$, (48) and (49) clearly imply that $\phi(s) \rightarrow +\infty$ as $s \rightarrow 0$, which shows that Σ is complete. Finally, we have that

$$\lim_{s \rightarrow 0} \phi'(s) = \lim_{s \rightarrow 0} \frac{\varrho(s)}{\sqrt{1-\varrho^2(s)}} = -\infty,$$

proving that Σ is asymptotic to the vertical hyperplane $\mathcal{E}_0 \times [0, +\infty)$ (Fig. 15).

(ii) Consider the function $\varrho := \tau_{-1}|_{(-\infty, 0)}$, where τ_{-1} is as in Proposition 8. Given $\mu < 0$, let Σ be the (\mathcal{E}_s, ϕ) -graph determined by ϱ with height function ϕ given by

$$\phi(s) = \int_\mu^s \frac{\varrho(u)}{\sqrt{1-\varrho^2(u)}} du, \quad s \in (-\infty, 0).$$

Since ϱ is negative, ϕ is strictly decreasing. Moreover, proceeding as in the proof of (i), one concludes that

$$\lim_{s \rightarrow -\infty} \phi(s) = +\infty \quad \text{and} \quad \lim_{s \rightarrow 0} \phi(s) = -\infty,$$

which implies that Σ is complete and asymptotic to $\mathcal{E}_0 \times [0, -\infty)$, for $\phi'(s) \rightarrow -\infty$ as $s \rightarrow 0$ (Fig. 16). This finishes the proof of (ii).

Since Proposition 2 holds for $\alpha = \tanh$, the proofs of (iii) and (iv) are completely analogous to the ones given for assertions (ii) and (iii) of Theorem 1. □

Remark 9 For $r > 1$, we could have chosen the domain Ω in the Cauchy problem (41) to be $(\mathbb{R} - \{0\}) \times [-1, 1]$. However, it is easily checked that the r -translators obtained from the solutions τ_{s_0} with $s_0 < 0$ are just the reflections with respect to the vertical hyperplane $\mathcal{E}_0 \times \mathbb{R}$ of the ones obtained from the solutions τ_{-s_0} . The same goes for the one-parameter family of translators to MCF in Theorem 3-(i). More precisely, for any $\lambda > 0$, the translator to MCF obtained from the solution τ_λ such that $\tau_\lambda(0) = \lambda$ is

the reflection with respect to $\mathcal{E}_0 \times \mathbb{R}$ of the translator obtained from the solution $\tau_{-\lambda}$. Notice that reflections with respect to vertical hyperplanes are isometries of $\mathbb{H}^n \times \mathbb{R}$ which take r -translators to r -translators.

Proposition 9 and Theorem 3, together with the considerations of the above remark, give the following uniqueness result, whose proof is completely analogous to the one given for Proposition 6.

Proposition 10 *Let Σ be a connected hyperbolic r ($<n$)-translator in $\mathbb{H}^n \times \mathbb{R}$ which is a vertical graph over an open set of \mathbb{H}^n . If $r = 1$, up to an ambient isometry, Σ is an open set of a hyperbolic bowl soliton, a hyperbolic 1-grim reaper, or a hyperbolic 1-translating catenoid. If $r > 1$, up to an ambient isometry, Σ is an open set of a hyperbolic r -translating catenoid.*

7 Translators to Gaussian Curvature Flow in $\mathbb{Q}_\epsilon^n \times \mathbb{R}$

In this section, in analogy with the preceding ones, we consider invariant n -translators in $\mathbb{Q}_\epsilon^n \times \mathbb{R}$ (i.e., translators to the Gaussian curvature flow). With the notation of Sect. 3, we have that $\beta := 1/\alpha$ is one of the functions: \tan_ϵ , \coth , or the constant 1. Hence, when $r = n$, Eq. (17) becomes

$$\tau'(s) = n\sqrt{1 - \tau_n^2(s)}\beta^{n-1}(s), \tag{50}$$

whose associated Cauchy problem is

$$\begin{cases} y'(s) = n\sqrt{1 - y_n^2(s)}\beta^{n-1}(s), \\ y(s_0) = y_0, \quad (s_0, y_0) \in \Omega, \end{cases} \tag{51}$$

where $\Omega := I \times (-1, 1)$, being

$$I := \begin{cases} (-\infty, +\infty) & \text{if } \beta = \tan_\epsilon \text{ or } \beta = 1, \\ (0, +\infty) & \text{if } \beta = \coth. \end{cases}$$

Remark 10 In the rotational case, the parameter s is the radius of a geodesic sphere $S_s^{n-1} \subset \mathbb{Q}_\epsilon^n$, and so it takes only positive values. However, in this setting, the function $\beta = \tan_\epsilon$ is well defined in $(-\infty, +\infty)$, which allowed us to consider the Cauchy problem (51) for the rotational case in the region $\Omega = (-\infty, +\infty) \times (-1, 1)$. This shall give us a better understanding of the qualitative behavior of the solutions.

In the next propositions, we establish some fundamental properties of solutions to (51) (see Fig. 19). To accomplish that, it will be convenient to consider the cases n odd and n even separately.

Proposition 11 *Given an odd integer $n \geq 3$, and a point $(s_0, y_0) \in \Omega$, let τ be the solution of the Cauchy problem (51). Then, there exist $s_{\min} = s_{\min}(\tau)$ and $s_{\max} = s_{\max}(\tau)$ in I such that:*

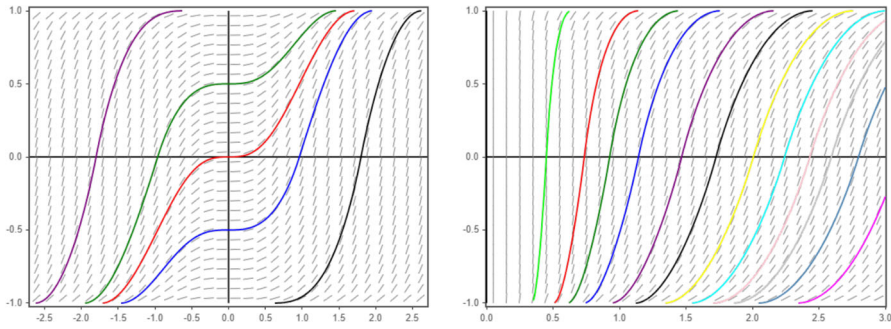

Fig. 19 Graphs of solutions to (51) for $(n, \beta) = (3, \tanh)$ (left), and $(n, \beta) = (3, \coth)$ (right)

- $(s_{\min}(\tau), s_{\max}(\tau))$ is the maximal interval of definition of τ ,
- the following equalities hold:

$$\lim_{s \rightarrow s_{\max}} \tau(s) = 1 \quad \text{and} \quad \lim_{s \rightarrow s_{\min}} \tau(s) = -1.$$

Proof Since n is odd, any solution to (51) is increasing. Also, in the case $\beta = \coth$, arguing just as in the proof of Proposition 9, we conclude that the graph of τ does not intersect the y -axis. Therefore, it suffices to prove that τ has no horizontal asymptotic lines.

Assume, by contradiction, that $[s_0, +\infty)$ is contained in the maximal interval on which τ is defined. Then, there exists $\mathcal{L} \in [\tau(s_0), 1]$ such that $\tau(s) \rightarrow \mathcal{L}$ as $s \rightarrow +\infty$. In this case, we necessarily have

$$\lim_{s \rightarrow +\infty} \tau'(s) = \lim_{s \rightarrow +\infty} \tau''(s) = 0. \tag{52}$$

Considering (50) and the first limit in (52), we easily conclude that $\mathcal{L} = 1$. Now, assuming s sufficiently large so that $\tau(s) \neq 0$, we get from a direct computation that

$$\tau''(s) = n\beta^{n-2}(s) \left(-\frac{\beta^n(s)}{\tau^{\frac{n-2}{n}}(s)} + (n-1)\sqrt{1-\tau^{\frac{2}{n}}(s)}\beta'(s) \right), \tag{53}$$

and then

$$\lim_{s \rightarrow +\infty} \tau''(s) = \begin{cases} -\infty & \text{if } \beta = \tan_0, \\ -n & \text{if } \beta \neq \tan_0, \end{cases}$$

which contradicts the second equality in (52).

In the same way we prove that, in the cases $\beta = \tan_\epsilon$ or $\beta = 1$, there is no $\mathcal{L} \in [-1, \tau(s_0)]$ such that $\lim_{s \rightarrow -\infty} \tau(s) = \mathcal{L}$. This finishes the proof. \square

Proposition 12 *Let $n \geq 3$ and τ be as in Proposition 11. Then, the function*

$$\phi(s) := \int_{s_0}^s \frac{\varrho(u)}{\sqrt{1 - \varrho^2(u)}} du, \quad \varrho = \tau^{1/n},$$

satisfies

$$\lim_{s \rightarrow s_{\max}} \phi(s) = \lim_{s \rightarrow s_{\min}} \phi(s) = +\infty.$$

Proof We follow closely the final part of the proof of Theorem 3-(i). Since

$$\lim_{s \rightarrow s_{\max}} \tau(s) = 1,$$

we have from (50) that $\lim_{s \rightarrow s_{\max}} \tau'(s) = 0$. So, we can extend τ smoothly to $[s_{\max}, +\infty)$ by setting $\tau(s) = 1$ for all $s \in [s_{\max}, +\infty)$. Considering this extension, we have that $\varrho^2(s_{\max}) = 1$, $(\varrho^2)'(s_{\max}) = 0$ and, from (53), that $(\varrho^2)''(s_{\max}) < 0$. In particular, the second order Taylor’s formula of ϱ^2 around s_{\max} reads as

$$\varrho^2(s) = 1 + \frac{1}{2}(\varrho^2)''(s_{\max})(s - s_{\max})^2 + f(s), \quad \lim_{s \rightarrow s_{\max}} \frac{f(s)}{(s - s_{\max})^2} = 0. \quad (54)$$

Setting $a := (\varrho^2)''(s_{\max})/2$, we have from (54) that

$$\lim_{s \rightarrow s_{\max}} \frac{\sqrt{1 - \varrho^2(s)}}{|s - s_{\max}|} = \sqrt{-a} > 0. \quad (55)$$

Also, considering (53), a direct computation gives that $(\varrho^2)'''(s_{\max})$ is well defined, that is, it is finite. Then, applying the l’Hôpital’s rule, we have from (54) that

$$\lim_{s \rightarrow s_{\max}} \frac{f(s)}{(s - s_{\max})^3} = \lim_{s \rightarrow s_{\max}} \frac{(\varrho^2)'(s) - 2a(s - s_{\max})}{3(s - s_{\max})^2} = \lim_{s \rightarrow s_{\max}} \frac{(\varrho^2)''(s) - 2a}{6(s - s_{\max})},$$

so that

$$\lim_{s \rightarrow s_{\max}} \frac{f(s)}{(s - s_{\max})^3} = \frac{(\varrho^2)'''(s_{\max})}{6} \neq \pm\infty. \quad (56)$$

Proceeding as in the proof of Theorem 3-(i), one can verify that the function

$$g(s) := \frac{1}{\sqrt{1 - \varrho^2(s)}} - \frac{1}{\sqrt{-a}(s_{\max} - s)}$$

is well defined and bounded in a neighborhood of s_{\max} .

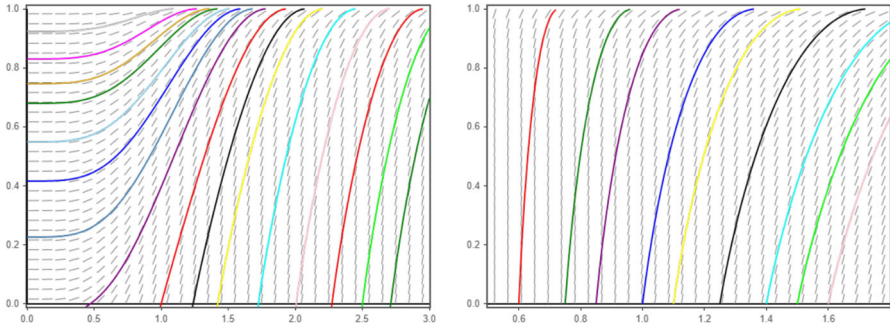

Fig. 20 Graphs of solutions to (51) on Ω_+ for $(n, \beta) = (4, \tanh)$ (left), and $(n, \beta) = (4, \coth)$ (right)

To conclude the proof, fix a small $\delta > 0$ such that $s_0 < s_{\max} - \delta$. Then, for all $s \in (s_{\max} - \delta, s_{\max})$, one has

$$\begin{aligned} \phi(s) &= \int_{s_0}^{s_{\max}-\delta} \frac{\varrho(u)}{\sqrt{1-\varrho^2(u)}} du + \int_{s_{\max}-\delta}^s \frac{\varrho(u)}{\sqrt{1-\varrho^2(u)}} du \\ &\geq \int_{s_0}^{s_{\max}-\delta} \frac{\varrho(u)}{\sqrt{1-\varrho^2(u)}} du + \varrho(s_{\max} - \delta) \int_{s_{\max}-\delta}^s \frac{1}{\sqrt{1-\varrho^2(u)}} du. \end{aligned} \tag{57}$$

But, by the definition of g ,

$$\begin{aligned} \int_{s_{\max}-\delta}^s \frac{1}{\sqrt{1-\varrho^2(u)}} du &= \int_{s_{\max}-\delta}^s g(u) du + \frac{1}{\sqrt{-a}} \int_{s_{\max}-\delta}^s \frac{du}{s_{\max}-u} \\ &= \int_{s_{\max}-\delta}^s g(u) du + \frac{1}{\sqrt{-a}} \log\left(\frac{\delta}{s_{\max}-s}\right), \end{aligned} \tag{58}$$

which implies that $\phi(s) \rightarrow +\infty$ as $s \rightarrow s_{\max}$. The proof that $\phi(s) \rightarrow +\infty$ as $s \rightarrow s_{\min}$ is analogous. □

In the two preceding propositions, the parts regarding the limits of τ and ϕ as $s \rightarrow s_{\max}$ have analogous versions for n even. To establish that, we have just to consider the Cauchy problem (51) on $\Omega_+ := [0, +\infty) \times [0, 1)$. Indeed, in this case, we have from (50) that the solutions to (51) are all increasing. Thus, we can argue as in the proofs of Propositions 11 and 12 to obtain the following results.

Proposition 13 *Given an even integer $n \geq 2$, and a point $(s_0, y_0) \in \Omega_+$, let τ be the solution of the Cauchy problem (51) in Ω_+ . Then, there exists $s_{\max} = s_{\max}(\tau)$ in I , $s_{\max} > 0$, such that (see Fig. 20)*

$$\lim_{s \rightarrow s_{\max}} \tau(s) = 1.$$

Fig. 21 Graphs of solutions to (60) for $(n, \beta) = (3, \tan_0)$. The red curve is the graph of the solution τ_* in the statement of Proposition 15 (Color figure online)

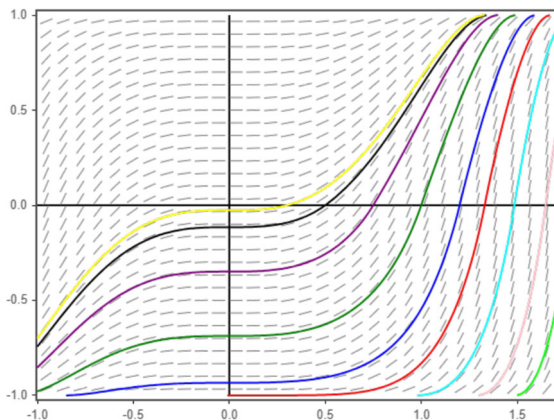

Proposition 14 Let $n \geq 2$ and τ be as in Proposition 13. Then, the function

$$\phi(s) := \int_{s_0}^s \frac{\varrho(u)}{\sqrt{1 - \varrho^2(u)}} du, \quad \varrho = \tau^{1/n},$$

satisfies $\lim_{s \rightarrow s_{\max}} \phi(s) = +\infty$.

7.1 Rotational Translators to n -MCF in $\mathbb{Q}_\epsilon^n \times \mathbb{R}$

Let us consider now rotational n -translators in $\mathbb{Q}_\epsilon^n \times \mathbb{R}$. In this case, $\beta = \tan_\epsilon$, so that (50) becomes

$$\tau'(s) = n\sqrt{1 - \tau^{\frac{2}{n}}(s) \tan_\epsilon^{n-1}(s)}, \tag{59}$$

whose associated Cauchy problem is:

$$\begin{cases} y'(s) = n\sqrt{1 - y^{\frac{2}{n}}(s) \tan_\epsilon^{n-1}(s)} \\ y(s_0) = y_0, \end{cases} \tag{60}$$

where $(s_0, y_0) \in \Omega := (-\infty, +\infty) \times (-1, 1)$.

Next, we establish a special property of the solutions to (60) when n is odd.

Proposition 15 Let $n \geq 3$ be an odd integer. Given $s_0 > 0$, let τ_{s_0} be the solution to (60) with initial condition $y(s_0) = 0$. Then, there exists $s_* > 0$ with the following properties (see Fig. 21):

- (i) $s_{\min}(\tau) > 0$ if and only if $s_0 > s_*$.
- (ii) The solution τ_* to (60) such that $\tau_*(s_*) = 0$ satisfies $s_{\min}(\tau_*) = 0$.

As a consequence, the following holds:

- (iii) For any $\mu > 0$, there exists a solution τ to (60) such that $s_{\min}(\tau) = \mu$.

Proof Consider the set

$$\Lambda := \{s_0 > 0; s_{\min}(\tau_{s_0}) \leq 0\}$$

and observe that any $s_0 > 0$ sufficiently close to 0 is a point of Λ . In addition, since graphs of distinct solutions do not intersect, if $\bar{s}_0 \in \mathbb{R} - \Lambda$, then $[\bar{s}_0, +\infty) \subset \mathbb{R} - \Lambda$. Therefore, either occurs: $\Lambda = (0, s_*)$ for some $s_* > 0$ or $\Lambda = (0, +\infty)$.

Assume, by contradiction, that $\Lambda = (0, +\infty)$. For $s_0 > 1$, one has that $\tau_{s_0}(s_0 - 1)$ is negative and stays bounded away from -1 as s_0 goes to infinity, since we are assuming $s_{\min}(\tau) \leq 0$ and, by Proposition 11, τ is increasing with limit -1 as $s \rightarrow s_{\min}(\tau)$. Consequently,

$$\lim_{s_0 \rightarrow \infty} \tau'(s_0 - 1) = \lim_{s_0 \rightarrow \infty} (n\sqrt{1 - (\tau(s_0 - 1))^{2/n}} \tan_{\epsilon}^{n-1}(s_0 - 1)) = +\infty. \tag{61}$$

For all $s \in (0, s_0)$, we have that $\tau_{s_0}(s) < 0$, which yields $(\tau_{s_0}(s))^{n-2} < 0$, since we are assuming n odd. In addition, for $\beta = \tan_{\epsilon}$, one has $\beta, \beta' > 0$ on $(0, +\infty)$. Considering these facts and equality (53), we conclude that $\tau'_{s_0} > 0$ on $(0, s_0)$. In particular, $\tau'(s_0 - 1) < \tau'(s)$ for all $s \in (s_0 - 1, s_0) \subset (0, s_0)$. Also, from (61), we can assume s_0 sufficiently large, so that $\tau'(s_0 - 1) > 1$. Then, we have

$$1 \geq \tau(s_0) - \tau(0) = \int_0^{s_0} \tau'(s) ds \geq \int_{s_0-1}^{s_0} \tau'(s) ds \geq \tau'(s_0 - 1) > 1,$$

which is a contradiction. Therefore, $\Lambda = (0, s_*)$ for some $s_* > 0$.

Now, since $s_* := \sup \Lambda$, it is clear that it satisfies (i) and (ii). Assertion (iii) follows from (i)–(ii) and the fact that the graphs of solutions to (60) foliate Ω . □

Proposition 16 *Given an integer $n \geq 2$, let τ_0 be the solution to (60) satisfying $\tau_0(0) = 0$. Then, for $\varrho_0 = \tau_0^{1/n}$, one has that the limits*

$$L_1 := \lim_{s \rightarrow 0} (\cot_{\epsilon}(s)\varrho_0(s)) \quad \text{and} \quad L_2 := \lim_{s \rightarrow 0} \varrho'_0(s)$$

are both finite.

Proof Analogous to the proof of Proposition 4. □

Theorem 4 *Let $n \geq 3$ be an odd integer. Then, the following assertions hold:*

- (i) *There exists a rotational strictly convex n -translator Σ_0 in $\mathbb{Q}_{\epsilon}^n \times \mathbb{R}$ (to be called the n -bowl soliton) which is a vertical graph over an open ball $B_R(o) \subset \Pi_0$ of radius $R > 0$. Moreover, Σ_0 is contained in the closed half-space $\mathbb{Q}_{\epsilon}^n \times [0, +\infty)$ with unbounded height, and is asymptotic to $\partial B_R(0) \times \mathbb{R}$ (Fig. 22).*
- (ii) *There exists a one-parameter family $\mathcal{K}_n = \{\mathcal{K}_{\lambda} \mid 0 < \lambda < 1\}$ of properly embedded rotational cones in $\mathbb{Q}_{\epsilon}^n \times \mathbb{R}$ with vertex at $o \in \Pi_0 := \mathbb{Q}_{\epsilon}^n \times \{0\}$ (to be called n -translating cones), which are all n -translators. Any $\mathcal{K}_{\lambda} \in \mathcal{K}_n$ is the union of two vertical graphs $\mathcal{G}_{\pm\lambda}$ defined on open balls $B_{R_{\pm}}(o) \subset \Pi_0$ of*

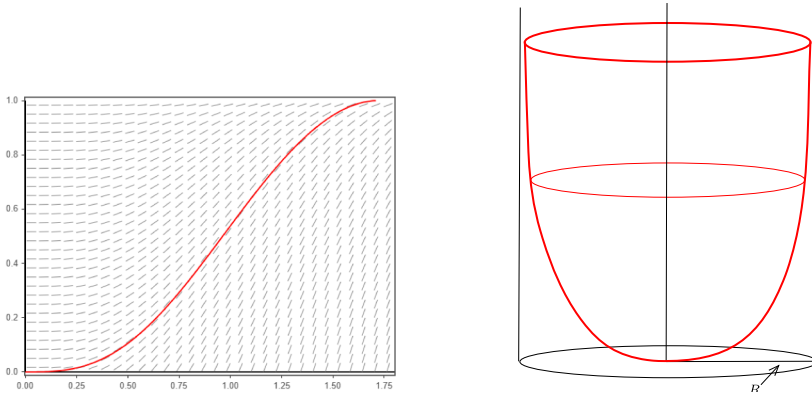

Fig. 22 The n -bowl soliton (right) and the solution to (60) that generates it (left)

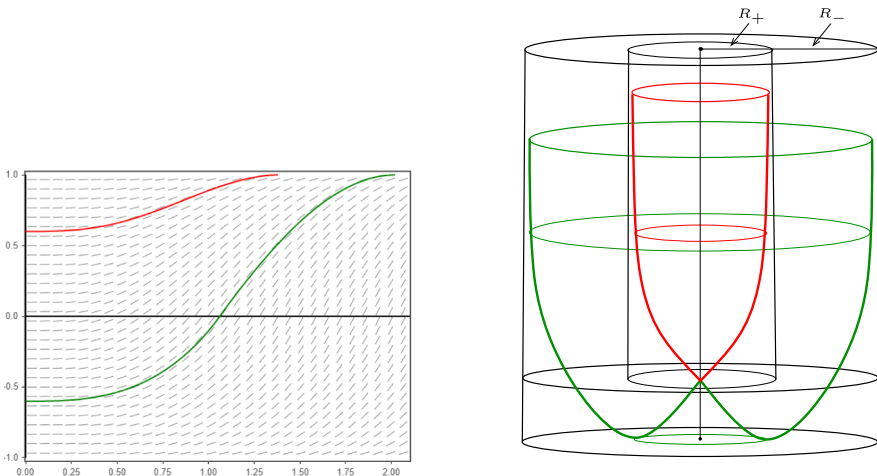

Fig. 23 An n -translating cone (right) and the solutions to (60) that generate it (left)

radiuses $R_{\pm} = R_{\pm}(\epsilon, n, \lambda)$, $R_- > R_+ > 0$, both with a conical singularity at o (Fig. 23). In addition, \mathcal{K}_{λ} has the following properties:

- It is contained in a half space and its height function is unbounded from above.
- Its graphs $\mathcal{G}_{\pm\lambda}$ are vertically asymptotic to the vertical cylinders $\partial B_{R_{\pm}}(o) \times \mathbb{R}$, respectively, and their angle functions $\Theta_{\pm\lambda}$ satisfy

$$\lim_{s \rightarrow 0} \Theta_{\pm\lambda}^2(s) = 1 - \lambda^2.$$

- It is C^2 -smooth, except at the vertex o , where it is singular, and on its $(n - 1)$ -sphere of minimal height, where it is C^2 -singular.

(iii) There exists a one-parameter family $\mathcal{C}_n = \{\Sigma_{\mu}; \mu \geq 0\}$ of properly embedded rotational n -translators in $\mathbb{Q}_{\epsilon}^n \times \mathbb{R}$ (to be called n -grim reapers). Each $\Sigma_{\mu} \in \mathcal{C}_n$

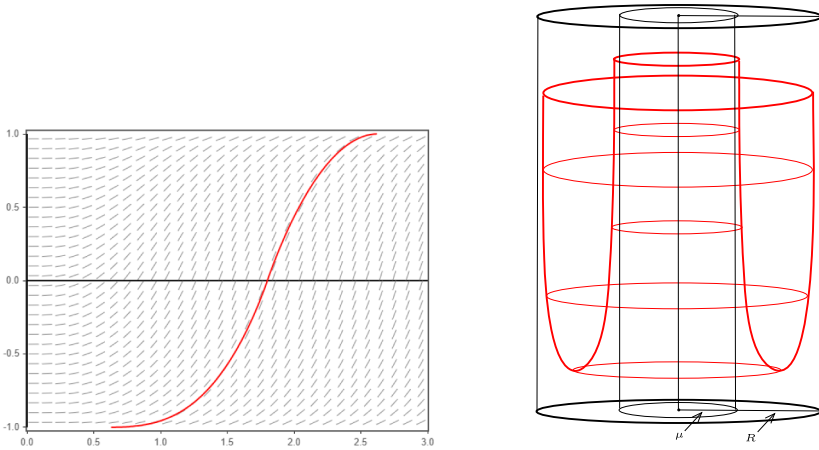

Fig. 24 An n -grim reaper (right) and the solution to (60) that generates it (left)

is a vertical graph over an annulus $B_R(o) - B_\mu(o)$, $R = R(\epsilon, n, \mu) > \mu$, and has the following properties (Fig. 24):

- It is contained in a half space, and its height function is unbounded from above.
- It is vertically asymptotic to the cylinders $\partial B_R(o) \times \mathbb{R}$ and $\partial B_\mu(o) \times \mathbb{R}$, where the latter reduces to a vertical line for $\mu = 0$.
- It is C^2 -singular along its $(n - 1)$ -sphere of minimal height.

Proof Given $\lambda \in [0, 1)$, let $\tau_{\pm\lambda} : [0, s_{\max}(\tau_{\pm\lambda})) \rightarrow \mathbb{R}$ be the solutions to (60) satisfying $\tau_{\pm\lambda}(0) = \pm\lambda$. Setting $\varrho_{\pm\lambda} := \tau_{\pm\lambda}^{1/n}$, it follows from Proposition 1 that the rotational graphs $\mathcal{G}_{\pm\lambda}$ with ϱ -functions $\varrho_{\pm\lambda}$ and height functions

$$\phi_{\pm\lambda}(s) = \int_0^s \frac{\varrho_{\pm\lambda}(u)}{\sqrt{1 - \varrho_{\pm\lambda}^2(u)}} du, \quad s \in [0, s_{\max}(\tau_{\pm\lambda})],$$

are both n -translators in $\mathbb{Q}_\epsilon^n \times \mathbb{R}$. By Proposition 11, $\varrho_{\pm\lambda}(s) \rightarrow 1$ as $s \rightarrow s_{\max}(\tau_{\pm\lambda})$, which implies that $\phi'_{\pm\lambda}(s) \rightarrow +\infty$ as $s \rightarrow s_{\max}(\tau_{\pm\lambda})$. In addition, Proposition 12 gives that $\phi_{\pm\lambda}$ are both unbounded. Therefore, setting $R_\pm := s_{\max}(\tau_{\pm\lambda})$ and $\ell := \{o\} \times \mathbb{R}$ for the axis of rotation of $\mathcal{G}_{\pm\lambda}$, we have that $\mathcal{G}_{\pm\lambda}$ are asymptotic to $\partial B_{R_\pm}(o) \times \mathbb{R}$, respectively. Notice that $R_+ < R_-$. Otherwise, the graphs $\mathcal{G}_{\pm\lambda}$ would intersect.

For $\lambda = 0$, it follows from Proposition 16 and equalities (6) (for $\alpha = \cot \epsilon$) that $\Sigma_0 := \mathcal{G}_0$ is C^2 and strictly convex, which proves (i).

Analogously, for $\lambda > 0$, \mathcal{G}_λ is C^2 -smooth on $\mathcal{G}_\lambda - \{o\}$. Regarding $\mathcal{G}_{-\lambda}$, there exists $s_0 > 0$ such that $\varrho_{-\lambda}(s_0) = 0$. Hence, $\phi_{-\lambda}$ is decreasing in $(0, s_0)$ and increasing in $(s_0, s_{\max}(\tau_{-\lambda}))$. Also, $\varrho'_\lambda(s_0) = +\infty$, since $\tau_{-\lambda}(s_0) = 0$. So, $\mathcal{G}_{-\lambda}$ is C^2 -singular on its $(n - 1)$ -sphere S of minimal height. Clearly, $\mathcal{G}_{-\lambda}$ is C^2 on the complement of $S \cup \{o\}$.

Now, observe that $\phi'_{\pm\lambda}(0) = \pm\lambda/\sqrt{1-\lambda^2}$, which implies that the angle functions $\Theta_{\pm\lambda}$ of $\mathcal{G}_{\pm\lambda}$ satisfy (cf. (9)):

$$\lim_{s \rightarrow 0} \Theta_{\pm\lambda}^2(s) = \frac{1}{1 + (\phi'_{\pm\lambda}(0))^2} = 1 - \lambda^2 < 1,$$

so that o is a conical singular point of both graphs $\mathcal{G}_{\pm\lambda}$.

It follows from the above considerations that, for each $\lambda > 0$, the cone

$$\mathcal{K}_\lambda := \mathcal{G}_\lambda \cup \mathcal{G}_{-\lambda}$$

is an n -translator, as stated. This proves (ii).

Now, to prove (iii), choose $\mu \geq 0$. By Proposition 15-(iii), there exists a solution τ_μ to (60) such that $s_{\min}(\tau_\mu) = \mu$. Setting $s_0 > 0$ for the point at which $\varrho_\mu := \tau_\mu^{1/n}$ vanishes, and defining $R := s_{\max}(\tau_\mu)$, we conclude as above that

$$\phi_\mu := \int_{s_0}^s \frac{\varrho_\mu(u)}{\sqrt{1 - \varrho_\mu^2(u)}} du, \quad s \in (\mu, R),$$

is the height function of a rotational n -translator Σ_μ in $\mathbb{Q}_\epsilon^n \times \mathbb{R}$. Furthermore, by Proposition 12, ϕ_μ is unbounded above and Σ_μ is asymptotic to both $B_\mu(o)$ and $B_R(o)$. Analogously to the n -translating cones, Σ_μ is C^2 -singular on its $(n - 1)$ -sphere of minimal height. This shows (iii) and finishes the proof. \square

Taking into account Propositions 13, 14, and 16, one can mimic the proof of Theorem 4 and then get the following result.

Theorem 5 *Let $n \geq 2$ be an even integer. Then, the following assertions hold:*

- (i) *There exists a rotational strictly convex n -translator Σ_0 in $\mathbb{Q}_\epsilon^n \times \mathbb{R}$ (to be called the n -bowl soliton) which is a vertical graph over an open ball $B_R(o) \subset \Pi_0$ of radius $R > 0$. Moreover, Σ_0 is contained in the closed half-space $\mathbb{Q}_\epsilon^n \times [0, +\infty)$ with unbounded height, and is asymptotic to $\partial B_R(o) \times \mathbb{R}$ (Fig. 22).*
- (ii) *There exists a one-parameter family $\mathcal{K}_n = \{\mathcal{K}_\lambda \mid 0 < \lambda < 1\}$ of properly embedded rotational half-cones in $\mathbb{Q}_\epsilon^n \times \mathbb{R}$ with vertex at $o \in \mathbb{Q}_\epsilon^n \times \{0\}$ (to be called peaked n -bowl soliton), which are all n -translators. Any $\mathcal{K}_\lambda \in \mathcal{K}_n$ is a vertical graph defined on an open ball $B_R(o) \subset \mathbb{Q}_\epsilon^n \times \{0\}$ of radius $R = R(\epsilon, n, \lambda)$ with a conical singularity at o . In addition, \mathcal{K}_λ has the following properties (Fig. 25):*
 - *It is contained in a half space and its height function is unbounded from above.*
 - *It is vertically asymptotic to the cylinder $\partial B_R(o) \times \mathbb{R}$, and its angle function Θ_λ satisfies*

$$\lim_{s \rightarrow 0} \Theta_\lambda^2(s) = 1 - \lambda^2.$$

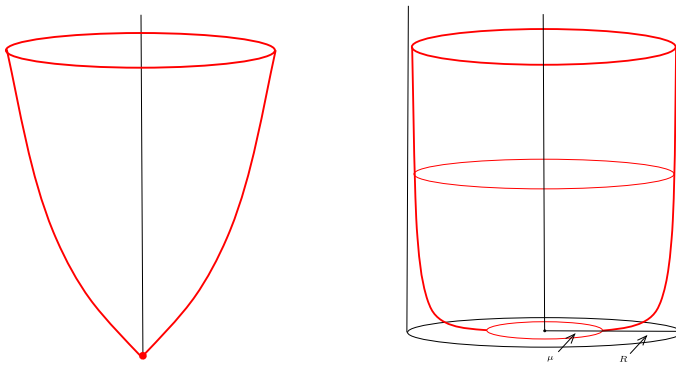

Fig. 25 Peaked n -bowl soliton (left) and n -grim reaper with boundary (right)

(iii) *There exists a one-parameter family $\mathcal{G}_n = \{\Sigma_\mu; \mu > 0\}$ of properly embedded rotational n -translators in $\mathbb{Q}_\epsilon^n \times \mathbb{R}$ (to be called n -grim reapers) with nonempty boundary. Each $\Sigma_\mu \in \mathcal{G}_n$ is a vertical graph over an annulus $B_R(o) - B_\mu(o)$, $R = R(\epsilon, n, \mu) > \mu$, and has the following properties (Fig. 25):*

- *It is contained in a half space, and its height function is unbounded from above.*
- *It is vertically asymptotic to the cylinder $\partial B_R(o) \times \mathbb{R}$ and tangent to $\mathbb{H}^n \times \{0\}$ along its boundary $\partial \Sigma_\mu = \partial B_\mu(o)$.*

Remark 11 Given $s_0 > 0$, let τ_{s_0} be the solution to (60) with initial condition $y(s_0) = 0$. By the continuity of solutions with respect to initial conditions, we have that the restriction of τ_{s_0} to the interval where it is positive converges uniformly to the solution τ_0 satisfying $\tau_0(0) = 0$ as $s_0 \rightarrow 0$. Consequently, the corresponding subset of the grim reaper converges (in compact sets) to the n -bowl soliton Σ_0 (compare with Remark 5).

In view of the results of Propositions 11–16, as well as the proofs of Theorems 4 and 5, we see that all solutions to (60) have been considered for obtaining the n -translators in these theorems. Therefore, as stated below, we have for rotational n -translators a uniqueness result which is analogous to that of Proposition 6.

Proposition 17 *Let Σ be a connected rotational n -translator in $\mathbb{Q}_\epsilon^n \times \mathbb{R}$ which is a vertical graph over an open set of \mathbb{Q}_ϵ^n . Then, Σ is an open set of one of the following hypersurfaces: an n -bowl soliton, an n -translating cone, an n -grim reaper, or a peaked n -bowl soliton.*

7.2 Parabolic Translators to n -MCF in $\mathbb{H}^n \times \mathbb{R}$

We shall consider now parabolic n -translators in $\mathbb{H}^n \times \mathbb{R}$, i.e., those invariant by horizontal parabolic translations. In this case, (50) becomes

$$\tau'(s) = n\sqrt{1 - \tau_n^2(s)}, \tag{62}$$

Fig. 26 Graphs of solutions to (63) for $n = 3$

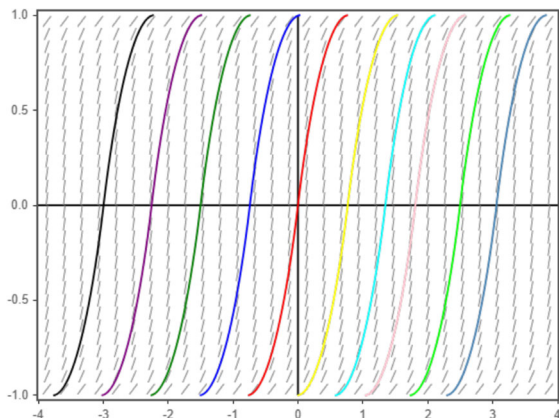

and the associated Cauchy problem is

$$\begin{cases} y'(s) = n\sqrt{1 - y^{\frac{2}{n}}(s)} \\ y(s_0) = y_0, \quad (s_0, y_0) \in \Omega, \end{cases} \tag{63}$$

where $\Omega := (-\infty, +\infty) \times (-1, 1)$.

Considering Propositions 11–14 in the parabolic setting, that is, for $\beta = 1$, we obtain the following result, whose proof is analogous to the one given for Theorem 4.

Theorem 6 *Let $n \geq 2$ be an integer. Then, the following assertions hold:*

- (i) *If n is odd, there exists a parabolic n -translator Σ in $\mathbb{H}^n \times \mathbb{R}$ (to be called the parabolic n -grim reaper) which has the following properties (Fig. 27):*
 - Σ is a vertical graph over the open region of \mathbb{H}^n bounded by two parallel horospheres \mathcal{H}_{\pm} . In particular, Σ is homeomorphic to \mathbb{R}^n .
 - The height of Σ is bounded from below and unbounded from above, and Σ is vertically asymptotic to both cylinders $\mathcal{H}_{\pm} \times \mathbb{R}$.
 - Σ is C^2 -singular along the horosphere of minimal height.
- (ii) *If n is even, there exists a parabolic n -translator Σ in $\mathbb{H}^n \times \mathbb{R}$ with nonempty boundary (to be called the parabolic n -grim reaper) which has the following properties (Fig. 27):*
 - Σ is a vertical graph over the open region of \mathbb{H}^n bounded by two parallel horospheres \mathcal{H}_0 and \mathcal{H}_+ .
 - The height of Σ is bounded from below and unbounded from above.
 - Σ is tangent to $\mathcal{H}_0 \times \{0\}$, where it reaches its minimal height, and it is vertically asymptotic to $\mathcal{H}_+ \times \mathbb{R}$.

Remark 12 The considerations of Remark 8 apply here. More precisely, given $s_0 \in \mathbb{R}$, denote by τ_{s_0} the solution to (63) with initial condition $y(s_0) = 0$. It is easily checked that (see Fig. 26):

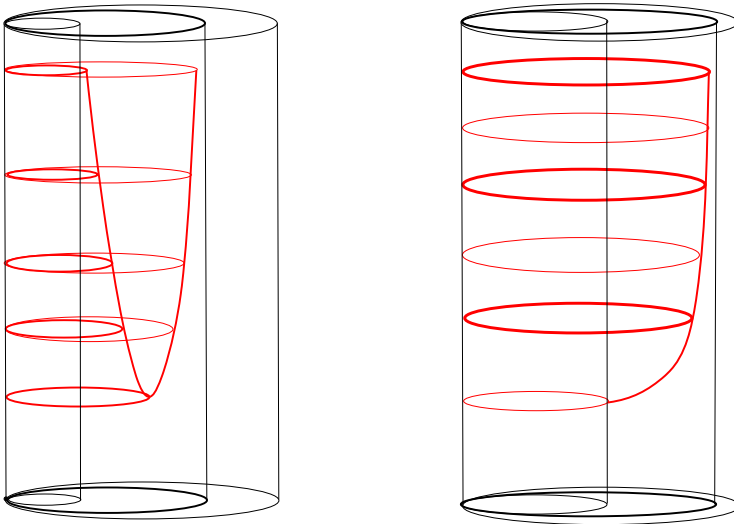

Fig. 27 The parabolic n -grim reaper for n odd (left) and n even (right)

$$\tau_{s_0}(s) = \tau_0(s - s_0) \quad \forall s \in (s_{\min}(\tau_{s_0}), s_{\max}(\tau_{s_0})),$$

which implies that all (\mathcal{H}_s, ϕ) -graphs obtained from the solutions τ_{s_0} are congruent to the one obtained from τ_0 .

As it was for the parabolic $r < n$ case (cf. Proposition 7), the following uniqueness result holds for parabolic n -translators.

Proposition 18 *Let Σ be a connected parabolic n -translator in $\mathbb{H}^n \times \mathbb{R}$ which is a vertical graph over an open set of \mathbb{H}^n . Then, up to an ambient isometry, Σ is an open set of a parabolic n -grim reaper.*

7.3 Hyperbolic Translators to n -MCF in $\mathbb{H}^n \times \mathbb{R}$

Concluding this section, we shall consider hyperbolic n -translators in $\mathbb{H}^n \times \mathbb{R}$, i.e., those invariant by horizontal hyperbolic translations. In this setting, Eq. (40) becomes

$$\tau'(s) = n\sqrt{1 - \tau_n^{\frac{2}{n}}(s) \coth^{n-1}(s)}, \tag{64}$$

so that the associated Cauchy problem is

$$\begin{cases} y'(s) = n\sqrt{1 - y_n^{\frac{2}{n}}(s) \coth^{n-1}(s)}, \\ y(s_0) = y_0, \quad (s_0, y_0) \in \Omega, \end{cases} \tag{65}$$

where $\Omega := (0, +\infty) \times (-1, 1)$.

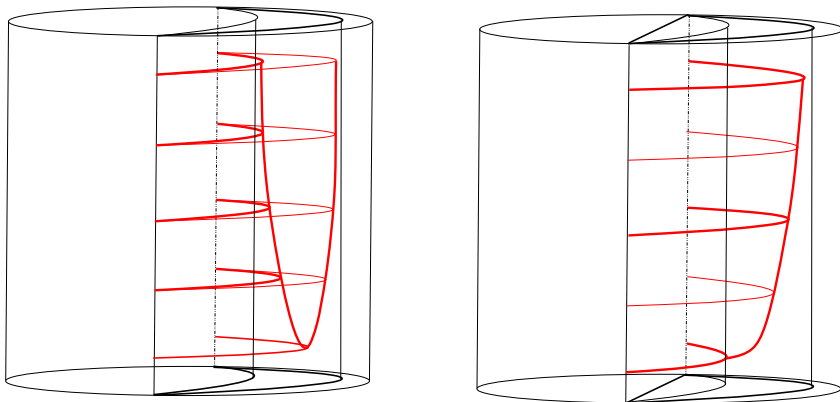

Fig. 28 Hyperbolic n -grim reaper for n odd (left) and n even (right)

Analogously to the parabolic case in the preceding subsection, applying Propositions 11–14 as in the proof of Theorem 4 yields the following result.

Theorem 7 *Let $n \geq 2$ be an integer. Then, the following assertions hold:*

- (i) *If n is odd, there exists a one parameter family $\mathcal{G}_n := \{\Sigma_\lambda; \lambda > 0\}$ of hyperbolic n -translators in $\mathbb{H}^n \times \mathbb{R}$ (to be called hyperbolic n -grim reapers) which has the following properties (Fig. 28):*
 - *For each $\lambda > 0$, Σ_λ is a vertical graph over the open region of \mathbb{H}^n bounded by two parallel equidistant hypersurfaces \mathcal{E}_\pm . In particular, Σ_λ is homeomorphic to \mathbb{R}^n .*
 - *The height of Σ_λ is bounded from below and unbounded from above, and Σ_λ is vertically asymptotic to both cylinders $\mathcal{E}_\pm \times \mathbb{R}$.*
 - *Σ_λ is C^2 -singular along its equidistant hypersurface of minimal height.*
- (ii) *If n is even, there exists a one parameter family $\mathcal{G}_n := \{\Sigma_\lambda; \lambda > 0\}$ of hyperbolic n -translators in $\mathbb{H}^n \times \mathbb{R}$ (to be called hyperbolic n -grim reapers) which has the following properties (Fig. 28):*
 - *For each $\lambda > 0$, Σ_λ is a vertical graph over the open region of \mathbb{H}^n bounded by two parallel equidistant hypersurfaces \mathcal{E}_\pm .*
 - *The height of Σ_λ is bounded from below and unbounded from above.*
 - *Σ_λ is tangent to $\mathbb{H}^n \times \{0\}$, where it reaches its minimal height, and it is vertically asymptotic to $\mathcal{E}_+ \times \mathbb{R}$.*

Remark 13 As in the case $r < n$ (cf. Remark 9), the n -translators obtained from the subfamily $\{\mathcal{E}_s; s < 0\}$ (of the family of equidistant hypersurfaces of a totally geodesic hypersurface \mathcal{E}_0 of \mathbb{H}^n) are congruent to those obtained in Theorem 7.

As it was for the rotational and parabolic cases of the preceding subsections, the following uniqueness result for hyperbolic n -translators holds.

Proposition 19 *Let Σ be a connected hyperbolic n -translator in $\mathbb{H}^n \times \mathbb{R}$ which is a vertical graph over an open set of \mathbb{H}^n . Then, up to an ambient isometry, Σ is an open set of a hyperbolic grim reaper.*

8 Uniqueness Results

In this final section, we shall classify the invariant r -translators of $\mathbb{Q}_\epsilon^n \times \mathbb{R}$. In fact, we shall prove that, up to ambient isometries, any invariant r -translator of $\mathbb{Q}_\epsilon^n \times \mathbb{R}$ is one of those obtained in the preceding sections.

Definition 4 Given integers $n \geq 2$ and $r \in \{1, \dots, n\}$, an r -translator of $\mathbb{Q}_\epsilon^n \times \mathbb{R}$ will be called *fundamental* if it is congruent (see Remarks 3, 6–9, and 12–13) to one of the following invariant hypersurfaces:

- a vertical hyperplane, i.e., a cylinder over a totally geodesic hypersurface of \mathbb{Q}_ϵ^n (cf. Example 1);
- a cylinder over a sphere of \mathbb{Q}_ϵ^n , a horosphere of \mathbb{H}^n , or an equidistant hypersurface of \mathbb{H}^n (for $r = n$, cf. Example 1);
- a grim reaper (cf. Example 2, item (ii) of Theorem 3; item (iii) of Theorems 4 and 5, and Theorems 6 and 7);
- a bowl soliton (cf. item (i) of Theorems 1–5);
- a translating catenoid (cf. items (ii) and (iii) of Theorems 1 and 2, and items (iii) and (iv) of Theorem 3);
- a translating cone (cf. Theorem 4-(ii));
- a peaked bowl soliton (cf. Theorem 5).

Remark 14 Regarding the asymptotic behavior of the fundamental translators of $\mathbb{Q}_\epsilon^n \times \mathbb{R}$, an interesting phenomenon occurs; *up to an ambient isometry, any two fundamental r -translators are asymptotic to each other, independently of the isometry groups that fix them.* Indeed, by the results of the theorems in the preceding sections, in all fundamental r -translators, the angle function “at infinity” is equal to the limit angle Θ_L (recall that $\Theta_L = 0$ if $\epsilon = 0$ or $r = n$).

Gathering all the uniqueness results obtained in the preceding sections; namely, Propositions 6, 7, 10, and 17–19, gives the following result.

Proposition 20 *Let Σ be a connected invariant r -translator in $\mathbb{Q}_\epsilon^n \times \mathbb{R}$ which is a vertical graph over an open set of \mathbb{Q}_ϵ^n . Then, Σ is an open set of one of the fundamental r -translators.*

By means of this last proposition, we classify now all invariant r -translators of $\mathbb{Q}_\epsilon^n \times \mathbb{R}$.

Theorem 8 *Let Σ be a connected invariant r -translator of $\mathbb{Q}_\epsilon^n \times \mathbb{R}$. Then, Σ is an open set of a fundamental r -translator.*

Proof Let us suppose first that Θ never vanishes on Σ . Then, Σ is given by a union of invariant vertical graphs. By Proposition 20, each such graph is contained in one

and only one of the fundamental r -translators. Then, since Σ is connected, the same is true for Σ .

Suppose now that Θ vanishes on an open set of Σ . Then, since Σ is invariant and connected, it must be contained in a cylinder over one of the following hypersurfaces of \mathbb{Q}_ϵ^n : a totally geodesic hyperplane, a geodesic sphere, a horosphere, or a equidistant hypersurface. These cylinders, of course, are all r -translators.

Finally, assume that the set $\Sigma' \subset \Sigma$ on which Θ never vanishes is open and dense in Σ . Then, from the first part of the proof, any connected component of Σ' is contained in one and only one fundamental translator to r -MCF. The result, then, follows from the connectedness of Σ . □

Remark 15 In [13], Lira and Martín considered translators to MCF in products $M \times \mathbb{R}$, where M is a Hadamard manifold endowed with a rotationally invariant metric. In their Theorem 12, they obtained a one-parameter family of translators which, for $M = \mathbb{H}^n$, coincides with the one-parameter family \mathcal{B} of hyperbolic bowl-solitons we obtained in Theorem 3-(i). Their methods, though, are different from ours. In addition, in their Theorem 13, they aim to list all possible invariant translators to MCF in the products $M \times \mathbb{R}$. However, for $M = \mathbb{H}^n$, the hyperbolic translating catenoids we obtained in Theorem 3-(ii) seem to be missing in their statement.

In our next two results, we classify the translators to r -MCF in $\mathbb{Q}_\epsilon^n \times \mathbb{R}$ whose r -th mean curvature is constant, as well as those which are isoparametric.

Theorem 9 *Let Σ be a connected r -translator in $\mathbb{Q}_\epsilon^n \times \mathbb{R}$ whose r -th mean curvature H_r is constant. Then, Σ is necessarily an open set of one of the following hypersurfaces:*

- a vertical cylinder over an r -minimal hypersurface of \mathbb{Q}_ϵ^n ,
- a vertical cylinder over an arbitrary hypersurface of \mathbb{Q}_ϵ^n (if $r = n$),
- the parabolic r -bowl soliton of $\mathbb{H}^n \times \mathbb{R}$.

Proof It follows from the hypothesis that the angle function Θ of Σ is a constant which, without loss of generality, we can assume nonnegative. Then, from [7, Corollary 4], Σ is locally an (M_s, ϕ) -graph (if $\Theta > 0$), an open set of a vertical cylinder $\Gamma \times \mathbb{R}$ over a hypersurface Γ of \mathbb{Q}_ϵ^n (if $\Theta = 0$), or an open set of a horizontal hyperplane (if $\Theta = 1$). Clearly, horizontal hyperplanes are not translators and, if $r < n$, $\Gamma \times \mathbb{R}$ is an r -translator if and only if Γ is r -minimal in \mathbb{Q}_ϵ^n . For $r = n$, $\Gamma \times \mathbb{R}$ is an r -translator for any hypersurface $\Gamma \subset \mathbb{Q}_\epsilon^n$.

So, we can assume that Σ is locally an (M_s, ϕ) -graph. Then, by (8), the associated ϱ function is a positive constant. From this and (6), we have that the r -th mean curvature H_r^s of M_s is given by $H_r^s = (-\varrho)^{-r} H_r$, which implies that H_r^s is constant. Hence, by [12, Theorem 1.1], the family M_s is isoparametric. Since H_r^s is not zero and is independent of s , each parallel M_s must be an open set of a horosphere of \mathbb{H}^n , which implies that Σ is an invariant parabolic r -translator. Then, from Theorem 8, Σ is an open set of a parabolic fundamental r -translator. However, the only such translator having constant r -th mean curvature is the parabolic r -bowl soliton of $\mathbb{H}^n \times \mathbb{R}$ (cf. Theorem 2-(i)). □

Theorem 10 *Let Σ be a connected isoparametric r -translator in $\mathbb{Q}_\epsilon^n \times \mathbb{R}$. Then, Σ is necessarily an open set of one of the following hypersurfaces:*

- a vertical hyperplane of $\mathbb{Q}_\epsilon^n \times \mathbb{R}$,
- a vertical cylinder over an isoparametric hypersurface of \mathbb{Q}_ϵ^n (if $r = n$),
- the parabolic r -bowl soliton of $\mathbb{H}^n \times \mathbb{R}$.

Proof It is immediate that a cylinder $\Gamma \times \mathbb{R}$ over a connected hypersurface Γ of \mathbb{Q}_ϵ^n is isoparametric in $\mathbb{Q}_\epsilon^n \times \mathbb{R}$ if and only if Γ is isoparametric in \mathbb{Q}_ϵ^n . Considering the classification of isoparametric hypersurfaces of \mathbb{Q}_ϵ^n (see Sect. 2.1), we conclude that the only such hypersurfaces which are r -minimal are the totally geodesic ones. Thus, since isoparametric hypersurfaces are necessarily CMC, assuming $\Gamma \times \mathbb{R}$ is an isoparametric r -translator, we have from Theorem 9 that Γ must be either a totally geodesic hyperplane of \mathbb{Q}_ϵ^n or, if $r = n$, an isoparametric hypersurface of \mathbb{Q}_ϵ^n .

Now, as proved in Theorem 2-(i), for any $r \in \{1, \dots, n - 1\}$, the parabolic r -bowl soliton Σ_L of $\mathbb{H}^n \times \mathbb{R}$ is isoparametric. In addition, by Theorem 9, Σ_L is the only noncylindrical r -translator which has constant mean curvature. The result, then, follows from this fact and the considerations of the preceding paragraph. \square

Given a hypersurface $\Sigma \subset \mathbb{Q}_\epsilon^n \times \mathbb{R}$, we will call a transversal intersection

$$\Sigma^t := \Sigma \bar{\cap} (\mathbb{Q}_\epsilon^n \times \{t\})$$

a horizontal section of Σ .

An evident property of any fundamental r -translator is that its angle function is constant along its horizontal sections. In our last result, as stated below, we characterize the translators to MCF in $\mathbb{Q}_\epsilon^n \times \mathbb{R}$ which have this property.

Theorem 11 *Let $\Sigma \subset \mathbb{Q}_\epsilon^n \times \mathbb{R}$ be a connected translator to MCF whose angle function Θ is constant on each horizontal section $\Sigma^t \subset \Sigma$. Then, one the following occurs:*

- (i) Σ is an open set of a vertical cylinder over a minimal hypersurface of \mathbb{Q}_ϵ^n .
- (ii) Σ is given locally by an (M_s, ϕ) -graph whose level hypersurfaces are isoparametric. In particular, if the parallels M_s are umbilical, then Σ is an open set of a fundamental translator to MCF in $\mathbb{Q}_\epsilon^n \times \mathbb{R}$.

Proof Let Σ' be the open set of Σ on which ΘT does not vanish, where T is the gradient of the height function of Σ in $\mathbb{Q}_\epsilon^n \times \mathbb{R}$ (see Sect. 2). If Σ' is empty, then Θ vanishes on Σ , since T cannot vanish on an open set of a translator in $\mathbb{Q}_\epsilon^n \times \mathbb{R}$. In this case, $H = \Theta = 0$ on Σ . Hence, by Theorem 9, (i) occurs.

Assume now that Σ' is nonempty. Since Θ is constant on each Σ^t , we have that $\nabla\Theta$ is parallel to T on Σ' . This, together with the identity $AT = -\nabla\Theta$, gives that T is a principal direction of Σ' . Hence, by [7, Theorem 6], Σ' is given locally by an (M_s, ϕ) -graph. Let us show that, for any such (M_s, ϕ) -graph, the parallels M_s are isoparametric. With this purpose, consider a horizontal section $\Sigma^t \subset \Sigma$. From [7, Lemma 1], the mean curvature H_t of Σ^t (as a hypersurface of \mathbb{Q}_ϵ^n) and the mean curvature H of Σ relate as

$$H_t = -\frac{1}{\sqrt{1 - \Theta^2}} \left(H - \frac{1}{\|T\|^2} \langle AT, T \rangle \right). \tag{66}$$

In addition, we have from [7, Theorem 6] that $\langle AT, T \rangle / \|T\|^2$ is constant on Σ^t . Since $H = \Theta$ on Σ , it follows from (66) that H_t is constant on Σ^t , which gives that the parallels M_s are indeed isoparametric, and so (ii) occurs. If, in addition, the parallels M_s are totally umbilical, then Σ is invariant. In this case, by Theorem 8, Σ is an open set of a fundamental translator to MCF. \square

Acknowledgements We would like to thank the referee for the careful reading and comments. We are also indebted to Álvaro Ramos and João P. dos Santos for their valuable suggestions. G. Pipoli is partially supported by INdAM-GNSAGA and PRIN 20225J97H5.

Declarations

Conflict of interest The authors declare no conflict of interest.

References

1. Altschuler, S.J., Wu, L.F.: Translating surfaces of the non-parametric mean curvature flow with prescribed contact angle. *Calc. Var. Partial Differ. Equ.* **2**(1), 101–111 (1994)
2. Andrews, B., Chow, B., Guenther, C., Langford, M.: *Extrinsic Geometric Flows*. Graduate Studies in Mathematics, vol. 206. American Mathematical Society, Providence (2020)
3. Bueno, A.: Translating solitons of the mean curvature flow in the space $\mathbb{H}^2 \times \mathbb{R}$. *J. Geom.* **109**, 42 (2018)
4. Cecil, T., Ryan, P.: *Geometry of Hypersurfaces*. Springer, New York (2015)
5. Clutterbuck, J., Schnürer, O.C., Schulze, F.: Stability of translating solutions to mean curvature flow. *Calc. Var.* **29**, 281–293 (2007)
6. de Lima, R.F.: Translating solitons to flows by powers of the Gaussian curvature in Riemannian products. *Arch. Math.* **120**, 437–448 (2023)
7. de Lima, R.F., Roitman, P.: Helicoids and catenoids in $M \times \mathbb{R}$. *Ann. Mat. Pura Appl.* **200**, 2385–2421 (2021)
8. de Lima, R.F., Manfio, F., dos Santos, J.P.: Hypersurfaces of constant higher order mean curvature in $M \times \mathbb{R}$. *Ann. Mat. Pura Appl.* **201**, 2979–3028 (2022)
9. Domínguez-Vázquez, M., Manzano, J.M.: Isoparametric surfaces in $\mathbb{E}(k, \tau)$ -spaces. *Ann. Sc. Norm. Super. Pisa Cl. Sci. (5)* **XXII**, 269–285 (2021)
10. Field, M.: *Essential Real Analysis*. Springer, New York (2017)
11. Huisken, G., Sinestrari, C.: Convexity estimates for mean curvature flow and singularities of mean convex surfaces. *Acta Math.* **183**(1), 45–70 (1999)
12. Jin, T., Ge, J.: On submanifolds whose tubular hypersurfaces have constant higher order mean curvatures. *Acta Math. Sin. Engl. Ser.* **32**(4), 474–498 (2016)
13. Lira, J.H.S., Martín, F.: Translating solitons in Riemannian products. *J. Differ. Equ.* **266**, 7780–7812 (2019)
14. Nelli, B., Pipoli, G., Russo, G.: On constant higher order mean curvature hypersurfaces in $\mathbb{H}^n \times \mathbb{R}$. Preprint. To appear in *Adv. Nonlinear Stud.* Available at <https://arxiv.org/pdf/2304.00349.pdf>
15. Pipoli, G.: Invariant translators of the solvable group. *Ann. Mat. Pura Appl.* **199**, 1961–1978 (2020)
16. Pipoli, G.: Invariant translators of the Heisenberg group. *J. Geom. Anal.* **31**, 5219–5258 (2021)

Publisher's Note Springer Nature remains neutral with regard to jurisdictional claims in published maps and institutional affiliations.

Springer Nature or its licensor (e.g. a society or other partner) holds exclusive rights to this article under a publishing agreement with the author(s) or other rightsholder(s); author self-archiving of the accepted manuscript version of this article is solely governed by the terms of such publishing agreement and applicable law.